



SALAMANDER BROILERS

CONTACT US:

Customer Service:
+1 (786) 5847439

Sales Team:
+1 (786) 8602528

Email:
sales@lfsusa.store

www.lfsusa.store

COMPETITOR SERIES®



C-SM-36-NG/LP

SALAMANDER BROILERS

- Stainless steel exterior and interior
- Dual valve controls for left and right-side independent operation
- Two (2) 21,500 BTU high efficiency ceramic infrared burners and standby pilots – totals 43,000 BTUs
- 1 Minute pre-heat time
- 4 position rack adjustments on Salamander Broiler
- One(1) removable broiler chrome rack
- Range mount kit for 36” range available upon request*
- Manual ignition of burners
- Migali Industries® Protection Plan: 2 Years Parts & Labor Warranty

Latam Food Service

MODEL	BURNERS	GAS SPECS	TOTAL BTU NG / LP	BTU PER BURNER - NG / LP	INTAKE TUBE PRESSURE (W.C.) NG / LP	NOZZLE NO. - NG / LP	CONTROL METHOD	CONTROL VALVE TYPE	EXTERIOR DIMENSIONS W X D X H	INTERIOR DIMENSIONS W X D X H	PACKAGED DIMENSIONS W X D X H	WEIGHT	PACKAGED WEIGHT
C-SM-36-NG	2	NG	43,000	21,500	5	NG47	Independent Manual Control	Pilot Light	36 x 18 x 17.3	31.8 x 15.2 x 4	40 x 24.6 x 25.4	144 lbs.	168 lbs.
C-SM-36-LP	2	LP	43,000	21,500	10	LP54	Independent Manual Control	Pilot Light	36 x 18 x 17.3	31.8 x 15.2 x 4	40 x 24.6 x 25.4	144 lbs.	168 lbs.

Optional wall mount bracket part # 1988-54

*Part Number: 1759-1562 - Connecting Rod for Salamander/Cheesemelter

NOTE: Altitudes over 2,000 feet may need high latitude orifice adjustments to deliver BTU output listed

FOR COMMERCIAL USE ONLY

NOTE: MIGALI® RESERVES THE RIGHT TO CHANGE SPECIFICATIONS WITHOUT NOTICE



TOLL FREE: 800.852.5292
WEB: www.migali.com



DIMENSIONAL DRAWINGS

C-SM-36-NG/LP

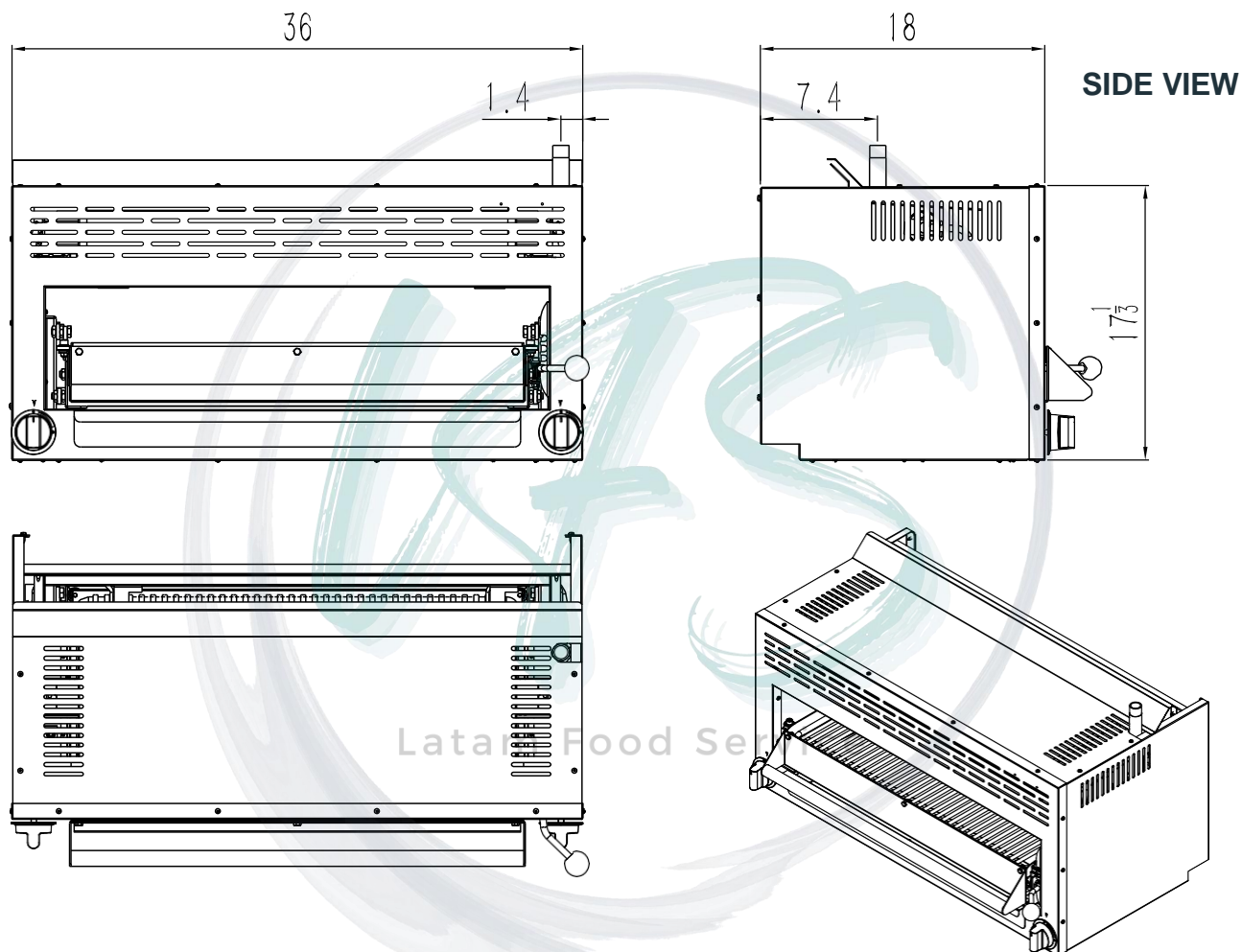

MIGALI® REMAINS AN AMERICAN FAMILY COMPANY SINCE 1955