



# STOCK POT STOVES

CONTACT US:

**Customer Service:**  
+1 (786) 5847439

**Sales Team:**  
+1 (786) 8602528

**Email:**  
sales@lfsusa.store

[www.lfsusa.store](http://www.lfsusa.store)

**COMPETITOR SERIES®**

**C-SPS-1-18**
**C-SPS-2-18**

# STOCK POT STOVES

- Heavy duty cast iron removable trivets
- 40,000 BTU manually controlled burners
- Bottom extra storage area
- Beautiful ergonomic design and easy to clean
- High polished, stainless steel exterior and chrome temperature knobs
- (4) adjustable stainless steel feet
- Comes standard as Natural Gas with L.P orifice kit for in-field conversion
- Migali Industries® Protection Plan: 2 Year Parts & Labor Warranty

MODEL	BURNERS	TOTAL BTU NG / LP	BTU PER BURNER - NG / LP	IN TAKE TUBE PRES- SURE (W.C.) NG / LP	NOZZLE NO. NG / LP	IGNITION	VALVE TYPE	TOP PLATE SIZE W X D	EXTERIOR DIMENSIONS W X D X H	PACKAGING DIMENSIONS W X D X H	WEIGHT	PACKAGED WEIGHT
C-SPS-1-18	2	80,000	40,000	4 / 10	#32 / #49	Manual	Pilot Light	(1) 17.8 x 20.9	18 x 20.9 x 22.8	20.9 x 24.8 x 25.2	106 lbs.	119 lbs.
C-SPS-2-18	4	160,000	40,000	4 / 10	#32 / #49	Manual	Pilot Light	(2) 17.8 x 20.9	18 x 41.7 x 22.8	20.9 x 45.7 x 25.2	202 lbs.	222 lbs.

Gas Connection: 3/4" NPT on the right  
 Clearance for combustible work area: 6" rear & 15" sides - Do Not Store Combustibles Underneath Unit  
 NOTE: Altitudes over 2,000 feet may need high latitude orifice adjustments to deliver BTU output listed

**FOR COMMERCIAL USE ONLY**

NOTE: MIGALI® RESERVES THE RIGHT TO CHANGE SPECIFICATIONS WITHOUT NOTICE



TOLL FREE: 800.852.5292  
 WEB: [www.migali.com](http://www.migali.com)



# DIMENSIONAL DRAWINGS

C-SPS-1-18

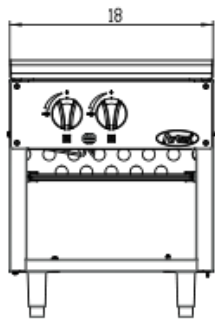

C-SPS-2-18

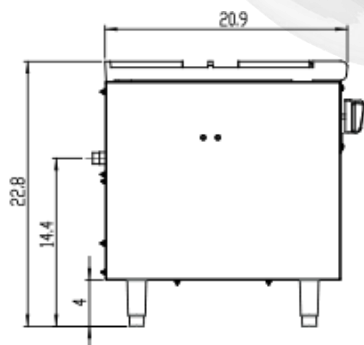
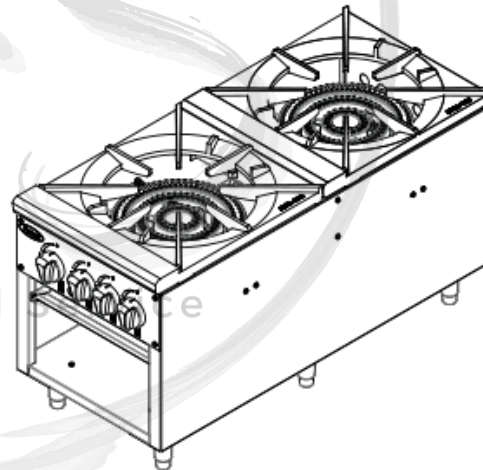
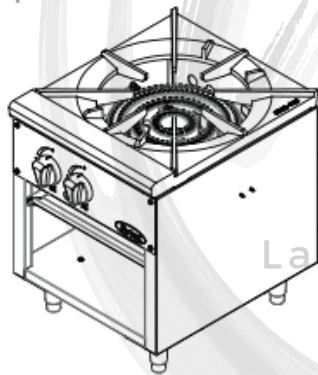
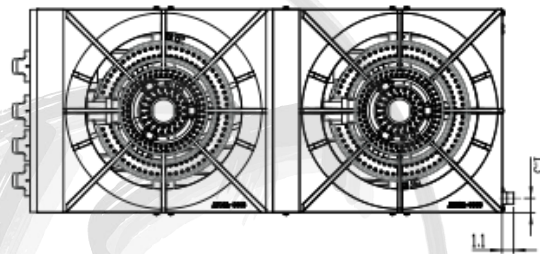
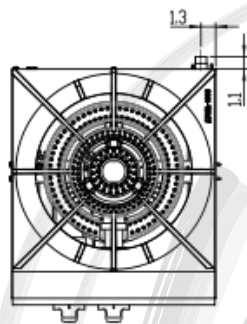
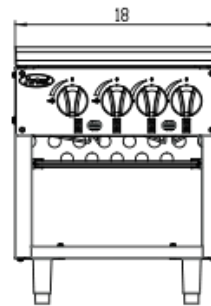

SIDE VIEW

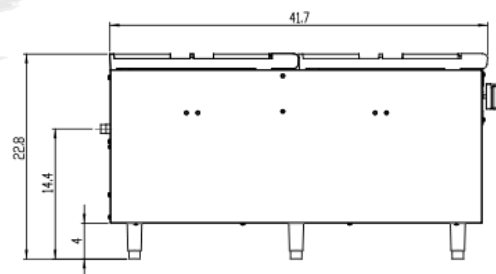

MIGALI® REMAINS AN AMERICAN FAMILY COMPANY SINCE 1955