



GRIDDLES

CONTACT US:

Customer Service:
+1 (786) 5847439

Sales Team:
+1 (786) 8602528

Email:
sales@lfsusa.store

www.lfsusa.store

COMPETITOR SERIES®

C-G24

C-G36

C-G48

GRIDDLES

- Manually controlled
- 3/4" thick on the griddle plate polished steel cooking surface for quick, even heating
- 30,000 BTU per "U" shape burner
- Large 20" deep cooking surface
- Removable slide out waste tray
- Beautiful ergonomic design and easy to clean
- (4) High polished, adjustable, stainless steel feet
- Stainless steel grease trough with wide opening for easy cleaning
- Comes standard as Natural Gas with L.P orifice kit for in-field conversion
- Migali Industries® Protection Plan: 2 Year Parts & Labor Warranty

Latam Food Service

MODEL	BURNERS	TOTAL BTU NG / LP	BTU PER BURNER NG / LP	IN TAKE TUBE PRES- SURE (W.C.) NG / LP	NOZZLE NO. NG / LP	IGNITION	VALVE TYPE	GRIDDLE PLATE WORKING AREA W X D X H	EXTERIOR DIMENSIONS W X D X H	PACKAGED DIMENSIONS W X D X H	WEIGHT	PACKAGED WEIGHT
C-G24	2	60,000	30,000	4/10	#37 / #51	Manual	Pilot Light	23.9 x 19.9 x .75	24 x 28.6 x 15.2	26.8 x 31.1 x 18.2	161 lbs.	195 lbs.
C-G36	3	90,000	30,000	4/10	#37 / #51	Manual	Pilot Light	35.7 x 19.9 x .75	36 x 28.6 x 15.2	38.6 x 31.1 x 18.2	232 lbs.	281 lbs.
C-G48	4	120,000	30,000	4/10	#37 / #51	Manual	Pilot Light	47.9 x 19.9 x .75	48 x 28.6 x 15.2	51.6 x 32.7 x 18.2	295 lbs.	416 lbs.

Gas Connection: 3/4" NPT on the right

Clearance for combustible work area: 6" rear & 15" sides - Do Not Store Combustibles Underneath Unit

NOTE: Altitudes over 2,000 feet may need high latitude orifice adjustments to deliver BTU output listed

FOR COMMERCIAL USE ONLY

NOTE: MIGALI® RESERVES THE RIGHT TO CHANGE SPECIFICATIONS WITHOUT NOTICE



TOLL FREE: 800.852.5292
WEB: www.migali.com



Conforms to ANSI STD Z83
116-2009 (D11), NSF/ANSI STD 4
& CSA STD 1-10-2009 (D11)



DIMENSIONAL DRAWINGS

C-G24

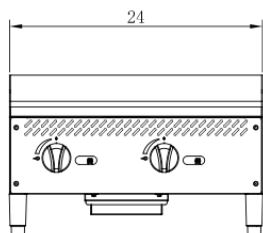

C-G36

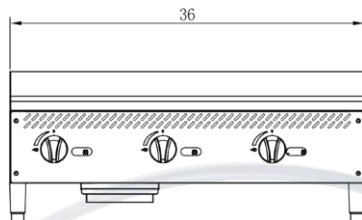

C-C48

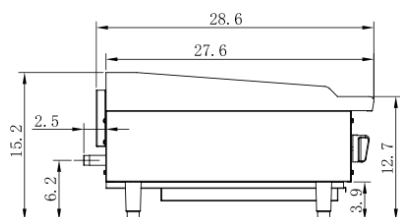
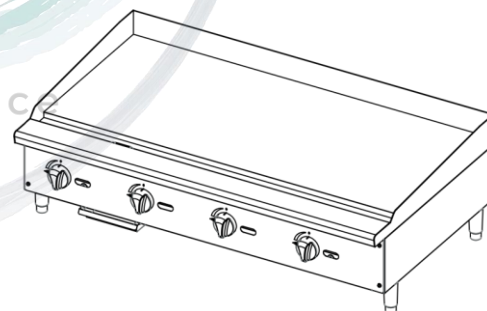
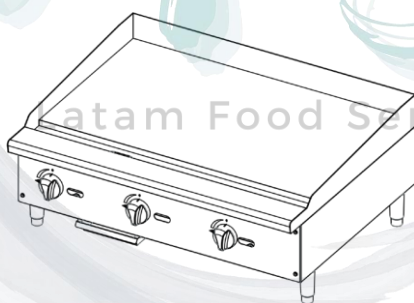
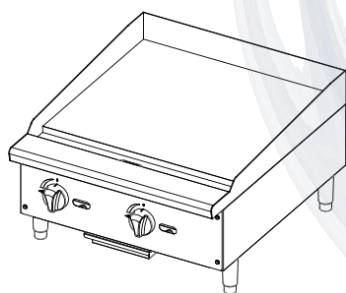
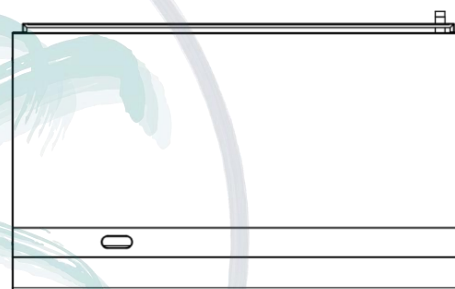
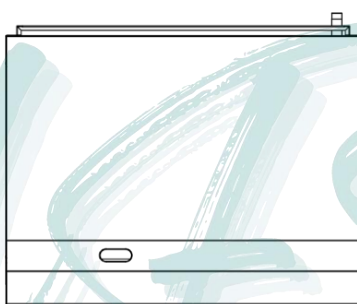
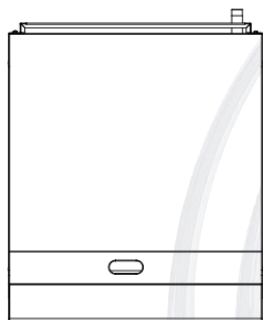
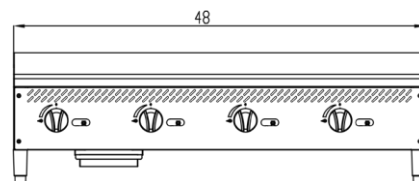

SIDE VIEW



MIGALI® REMAINS AN AMERICAN FAMILY COMPANY SINCE 1955