

**Hotel  
Restaurant  
Catering Equipment**



## **CONTACT US:**

**Customer Service**

**+1(786) 5847439**

**Sales team:**

**+1(786) 8602528**

**WEB SITE:**

**[www.lfsusa.store](http://www.lfsusa.store)**

**Email:**

**[sales@lfsusa.store](mailto:sales@lfsusa.store)**

**WHOLESALE- SWF-2  
LFSUSA.STORE**

- 8 Showcase Display Collection**
- Floor Standing Showcase Refrigerator
  - Showcase Refrigerator with Drawer
  - Gelato Showcase
  - Countertop Showcase Refrigerator & Warmer
  - Countertop Showcase Freezer
  - Sushi Display

**31 Counter Chiller & Freezer Collection**

- Counter Chiller & Freezer
- Counter Chiller & Freezer (Pass Through Type)
- Counter Chiller & Freezer with Remote Condensation Unit
- Pizza Cabinet
- Chef Base Refrigerator

**31 Banquet Cart Chiller & Warmer**



- Meat Ager
- Showcase Refrigerator with Drawer
- Salad Showcase Refrigerator
- Open Front Showcase

**4 New Arrival**

- Upright Chiller & Freezer
- Upright Chiller & Freezer (Pass Through Type)
- Upright Chiller & Freezer (Roll In)
- Upright Chiller & Freezer with Bakery Trays

**22 Upright Chiller & Freezer Collection**

**49 Beverage Collection**

- Under bar Cooler

**51 Customized Collection**

- Customized Collection

# Contents

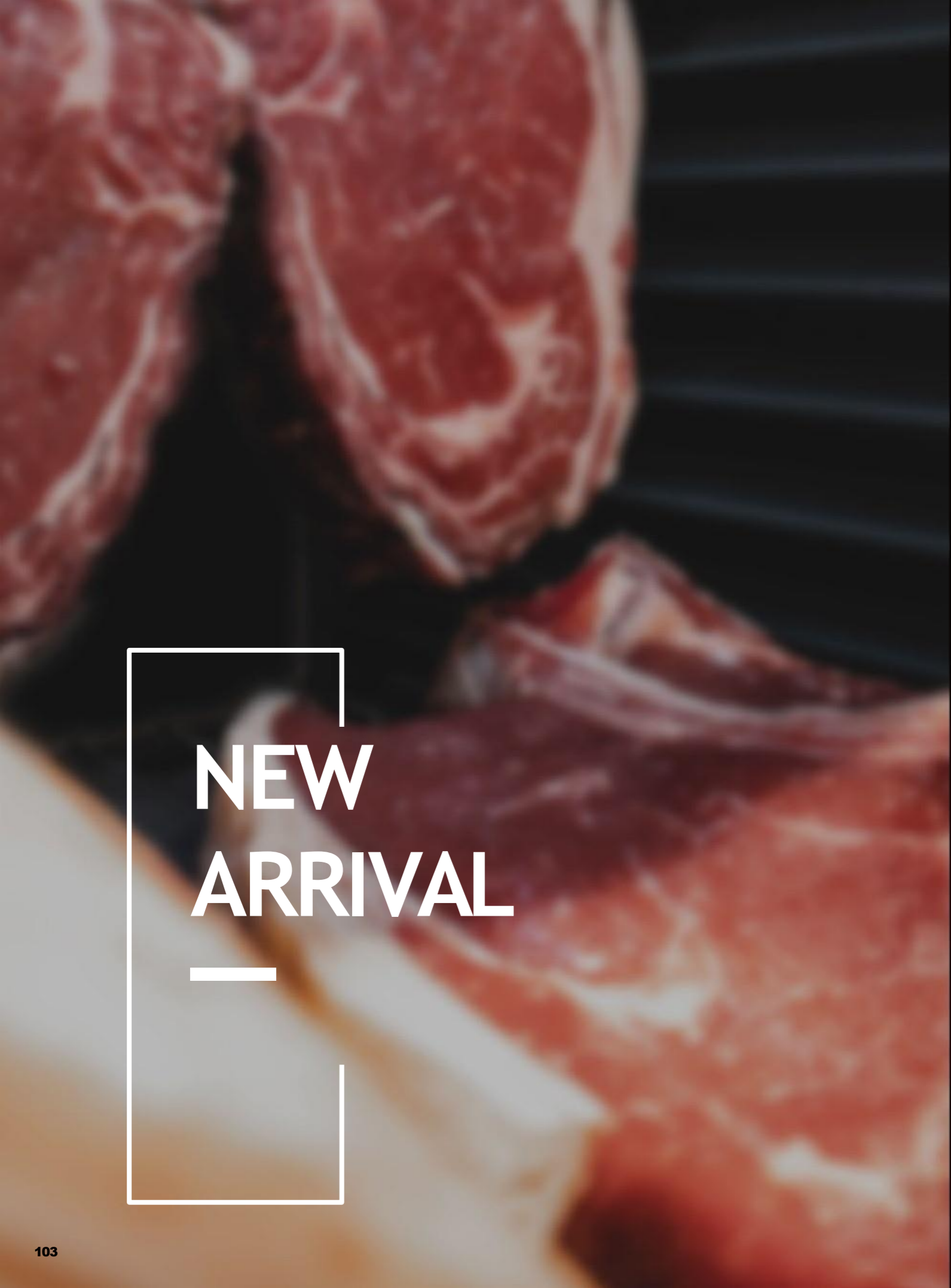

**NEW  
ARRIVAL**

**MEAT AGER**



NEW ARRIVAL

# MEAT AGER

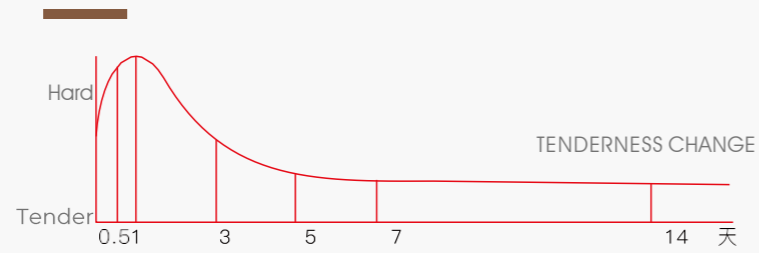

Color Variation During The Maturity

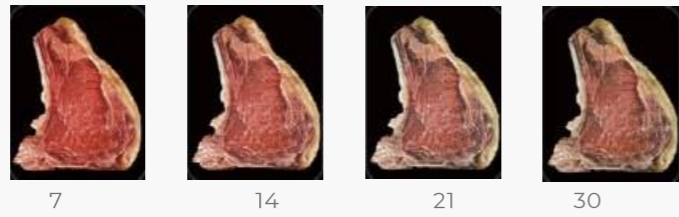

Put a batch of beef into the maturing fridge under 1°C-4°C / 60% - 90% humidity for maturing. Low temperature surrounding would restrain microorganism. Appropriate humidity could make the moisture of the meat evaporating slowly and make the meat tight with thick.



## TECHNICAL DATA



<b>Model</b>	MX1000
<b>Temp Range</b>	1°C ~ 4°C
<b>Humidity Range</b>	60% - 90%
<b>Capacity(L)</b>	400
<b>Rating Power (W)</b>	160
<b>Climate Class</b>	4
<b>External Dimension (mm)</b>	
<b>Width</b>	700
<b>Depth</b>	730+50
<b>Height</b>	1650
<b>Inner Dimension (mm)</b>	
585 (W) x 550 (D) x 1380 (H)	
<b>Packing Size (mm)</b>	
<b>Width</b>	770
<b>Depth</b>	840
<b>Height</b>	1860
<b>Weight (kgs)</b>	
<b>Net Weight !</b>	102
<b>Gross Weight</b>	122
<b>Refrigerant</b>	
<b>Type</b>	R600a
<b>Shipping</b>	
<b>Qty/20GP</b>	21
<b>Qty/40HQ</b>	42



Energy saving control, fan stops when door opens



UVC sterilization function



High transparent ultraviolet-proof glass door



Food grade liner and shelves



Precise digital controller



Active carbon for air filtration

Accessories



HANGER



HOOK



SHELVES



HIMALAYAN SALT BRICK



SALT TRAY

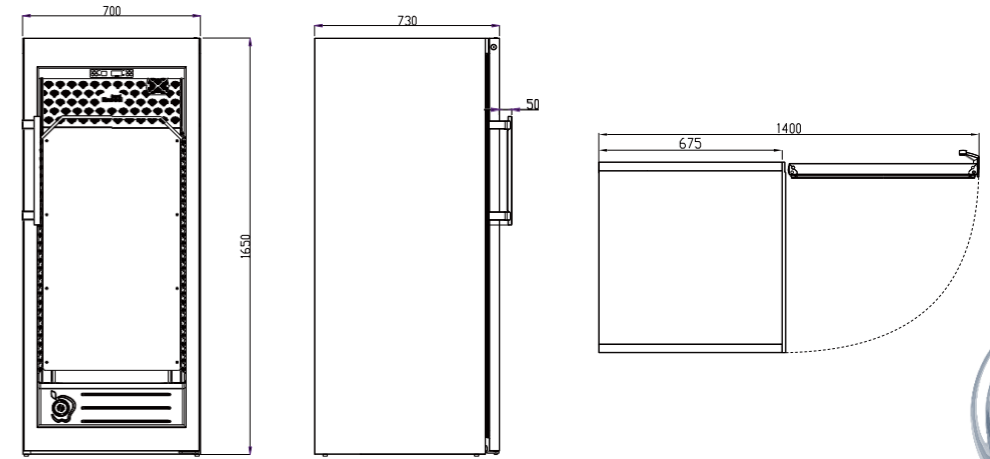

NEW ARRIVAL

# SHOWCASE REFRIGERATOR WITH DRAWERS



- Improved air cooling system ensuring effective air circulation
- Equipped with both baked castors and adjustable feet
- Automatic vaporizing the defrost water through the heat of discharge pipe of compressor
- Hang type ventilation grill, easy to remove for regular maintenance
- Patented semi frequency conversion technique, using electronic expansion valve with own control system, could adjust the parameter to reach to the optimal working performance automatically and save 30% energy consumption



Heating tempered glass, anti-condensation, energy saving and better visual effect



High quality imported compressor, energy saving, lower noise, and longer lifetime



Smart precise digital controller with large LCD display



Automatic defrost ensures the evaporator working to its optimum performance. Automatic vaporizing the defrosted water

## TECHNICAL DATA



Model	MM860V	MM880V
Temp Range	2°C~ 8°C	
Capacity(L)	380	500
Rating Power	1586	1876
Climate Class	4/5/7	
<b>External Dimension (mm)</b>		
Width	1800	2400
Depth	790	
Height	1200	
<b>Packing Size (mm)</b>		
Width	1885	2485
Depth	875	
Height	1330	
Qty of Drawer	6	8
<b>Weight (kgs)</b>		
Net Weight	378	473
Gross Weight	430	535
<b>Refrigerant</b>		
Type	R404a	R404a
<b>Shipping</b>		
Qty/20GP	6	4
Qty/40HQ	26	16

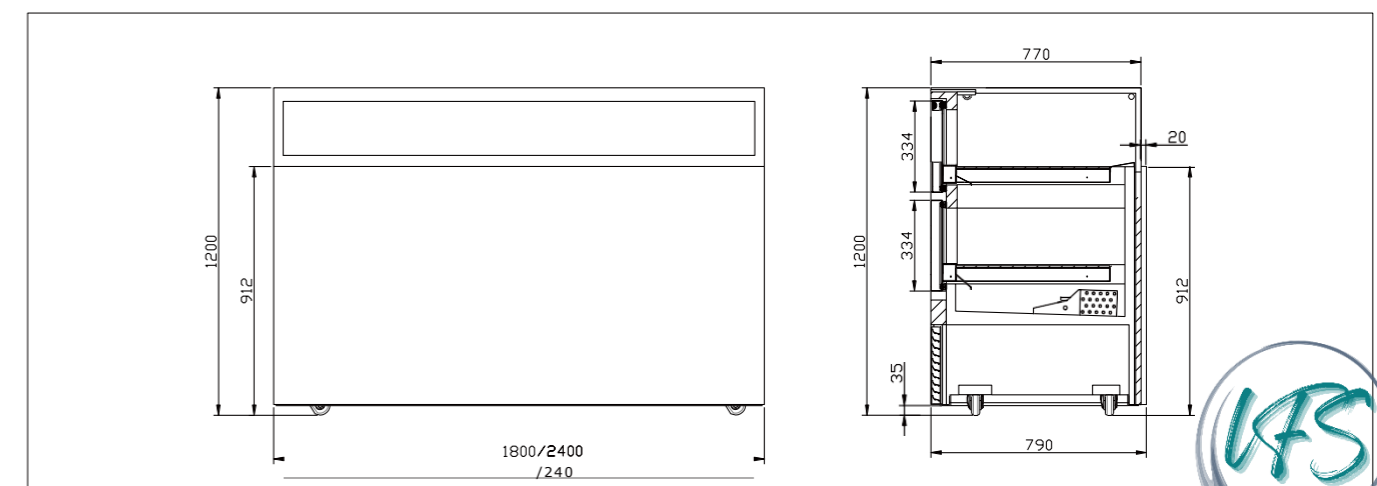

NEW ARRIVAL



# SALAD SHOWCASE REFRIGERATOR

- Improved air cooling system ensuring effective air circulation
- Equipped with both baked castors and adjustable feet
- Automatic vaporizing the defrost water through the heat of discharge pipe of compressor
- Hang type ventilation grill, easy to remove for regular maintenance
- Patented semi frequency conversion technique, using electronic expansion valve with own control system, could adjust the parameter to reach to the optimal working performance automatically and save 30% energy consumption

COLOUR

MARBLE

BLACK  WHITE

STAINLESS STEEL

PRIMARY SS  BLACK SS  WINE RED GOLD



With both 1/1 GN pans and glass shelves for food staff



High quality imported compressor and fan motor, energy saving, lower noise, and longer lifetime



Smart precise digital controller with large LCD display



Heating glass, anti-condensation, energy saving and better visual effect



Automatic defrost ensures the evaporator working to its optimum performance. Automatic vaporizing the defrosted water

## TECHNICAL DATA



Model	DSS0830	DSS0840	DSS0850	DSS0860
Temp Range	2°C~ 8°C			
Capacity	415	560	705	850
Rating Power	720	953	963	1158
Climate Class	4/5/7			
<b>External Dimension (mm)</b>				
Width	900	1200	1500	1800
Depth	830			
Height	1350			
<b>Packing Size (mm)</b>				
Width	985	1285	1585	1885
Depth	915			
Height	1500			
<b>Weight (kgs)</b>				
Net Weight	210	257	297	338
Gross Weight	242	295	342	389
Door Opening Direction	Back sliding door			
<b>Refrigerant</b>				
Type	R290			
<b>Shipping</b>				
Qty/20GP	12	10	7	6
Qty/40HQ	24	21	14	12

OPTIONAL REFRIGERANT : R134A

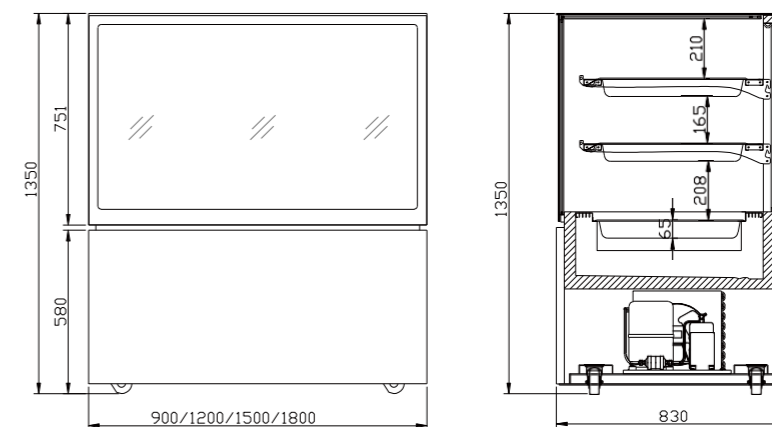

NEW ARRIVAL

# OPEN FRONT SHOWCASE



- Improved air cooling system ensuring effective air circulation
- Equipped with baked castors
- Automatic defrost function ensuring the evaporator working perfectly
- Automatic vaporizing the defrost water through the heat of discharge pipe of compressor



## TECHNICAL DATA

Model	NSC720A	NSC730A	NSC740A
Temp Range	0°C~ 5°C		
Capacity(L)	152	236	317
Rating Power (W)	550	700	1080
Climate Class	3		
<b>External Dimension (mm)</b>			
Width	610	890	1210
Depth	660		
Height	1350		
<b>Packing Size (mm)</b>			
Width	670	950	1270
Depth	790		
Height	1500		
<b>Weight (kgs)</b>			
Net Weight	120	173	218
Gross Weight	143	202	253
Door Opening Direction	Front curtain		
<b>Refrigerant</b>			
Type	R290		
<b>Shipping</b>			
Qty/20GP	23	14	11
Qty/40HQ	49	30	24



Smart precise digital controller, mobile sensor for options



Low-E side glass to prevent condensation



EC fans and high efficient cooling system for energy saving



Removable bottom front panel, easy to take apart for condenser cleaning. Various painted colors match different color request

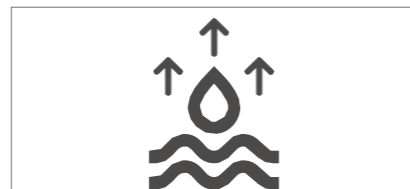

Smart water tray with heating control system

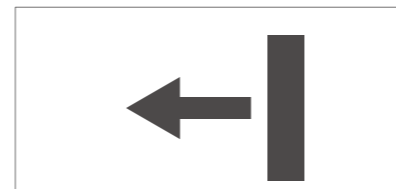

Pulling type compressor deck, easy for maintenance

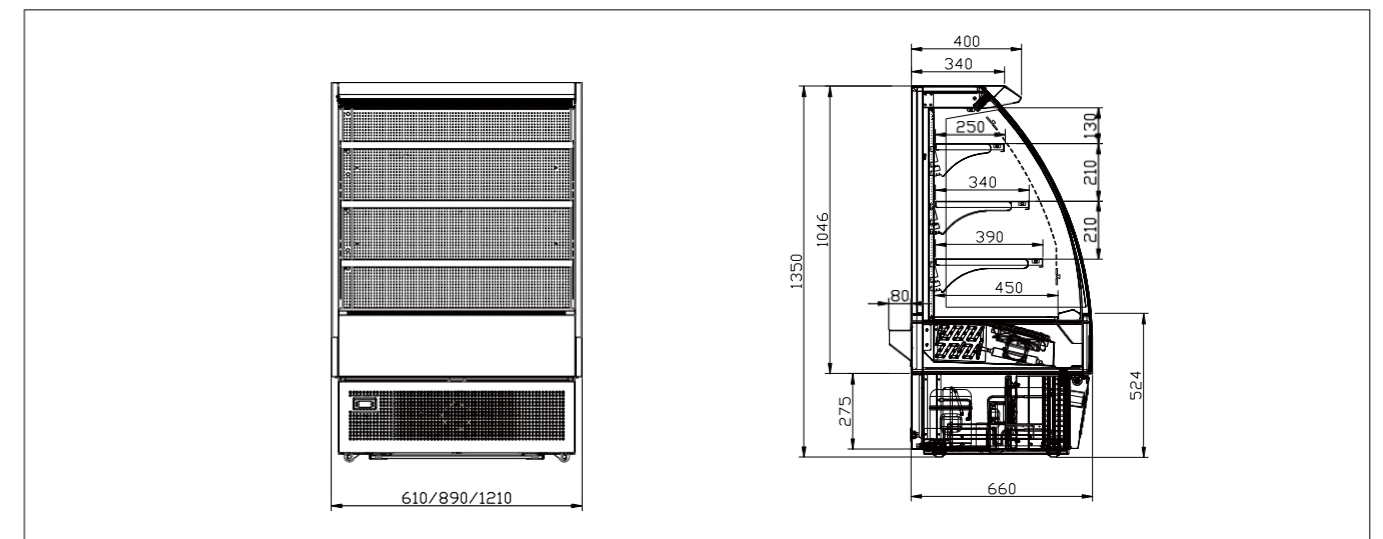



# SHOWCASE DISPLAY COLLECTION

LFSUSA.STORE





# FLOOR STANDING SHOWCASE REFRIGERATOR



- ITO heating glass, anti-condensation, energy saving and better visual effect
- Improved air cooling system ensuring effective air circulation
- Equipped with both baked castors and adjustable feet
- Automatic defrost function ensuring the evaporator working perfectly
- Automatic vaporizing the defrost water with the heat of discharge pipe of compressor
- Hang type ventilation grill, easy to remove for regular maintenance
- Patented semi frequency conversion technique, using electronic expansion valve with own control system, could adjust the parameter to reach to the optimal working performance automatically and save 30% energy consumption



Warm white or cool white LED lights illumination, perfectly displaying food, avoiding glaring



High quality imported compressor and fan motor, energy saving, lower noise, and longer lifetime



Smart precise digital controller with large LCD display



Improved door track and imported high quality bearing, easily using for sliding doors, smoothly and lower noise



Independent electric board cooling system could be taken out easily for replacement or maintenance



## FLOOR STANDING SHOWCASE REFRIGERATOR

### TECHNICAL DATA

Model	NLR730V	NLR740V	NLR750V	NLR760V	NLR780V	NLR830V	NLR840V	NLR850V	NLR860V	NLR880V
Temp Range	2°C~ 8°C									
Capacity (L)	190	260	325	395	530	235	315	400	480	645
Rating Power (W)	865	1075	1095	1295	1420	885	1095	1115	1315	1440
Climate Class	4/5/7									
<b>External Dimension (mm)</b>										
Width	900	1200	1500	1800	2400	900	1200	1500	1800	2400
Depth	680					800				
Height	1000					1000				
<b>Packing Size (mm)</b>										
Width	985	1285	1585	1885	2485	985	1285	1585	1885	2485
Depth	765					885				
Height	1130					1130				
<b>Weight (kgs)</b>										
Net Weight	153	190	222	255	291	171	210	245	275	314
Gross Weight	181	224	261	300	346	202	247	287	323	372
Shelves	2									
<b>Refrigerant</b>										
Type	R290									
Door Opening Direction	Back sliding doors (front doors for options)									
<b>Shipping</b>										
Qty/20GP	34	24	20	18	12	24	20	14	12	8
Qty/40HQ	72	54	44	36	24	52	44	30	26	16

Optional Refrigerant : R134a

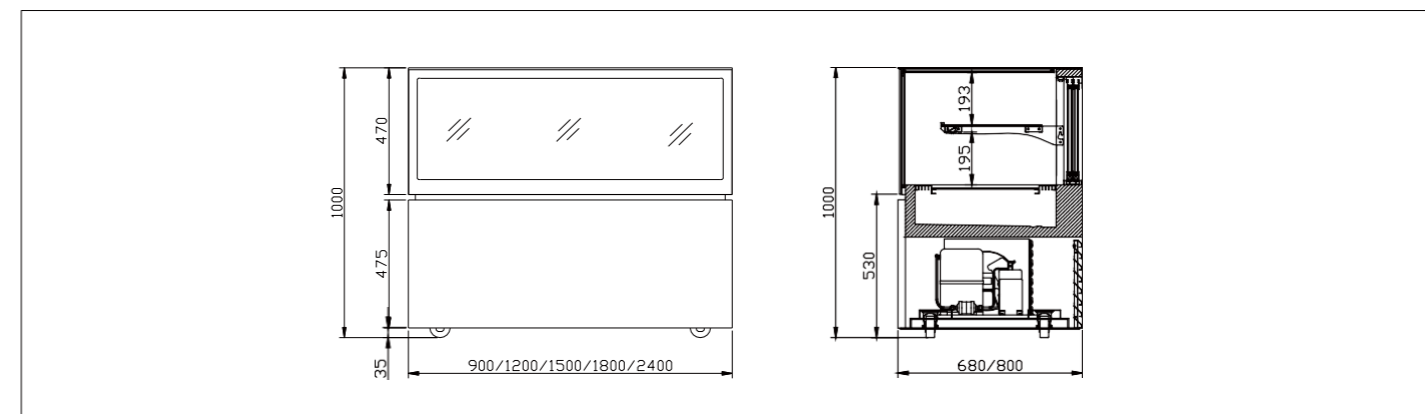



## FLOOR STANDING SHOWCASE REFRIGERATOR

### TECHNICAL DATA



Model	NR730V	NR740V	NR750V	NR760V	NR780V	NR830V	NR840V	NR850V	NR860V	NR880V
Temp Range	2°C~ 8°C									
Capacity(L)	285	385	485	585	790	350	470	595	715	965
Rating Power (W)	890	1100	1120	1320	1450	910	1120	1140	1340	1470
Climate Class	4/5/7									
<b>External Dimension (mm)</b>										
Width	900	1200	1500	1800	2400	900	1200	1500	1800	2400
Depth	680					800				
Height	1200					1200				
<b>Packing Size (mm)</b>										
Width	985	1285	1585	1885	2485	985	1285	1585	1885	2485
Depth	765					885				
Height	1330					1330				
<b>Weight (kgs)</b>										
Net Weight	174	215	254	291	331	194	234	279	314	356
Gross Weight	204	251	297	340	391	227	273	325	366	419
Shelves	3									
<b>Refrigerant</b>										
Type	R290									
Door Opening Direction	Back sliding doors (front doors for options)									
<b>Shipping</b>										
Qty/20GP	17	12	10	9	6	12	10	7	6	4
Qty/40HQ	72	54	44	36	24	52	44	30	26	16

Optional Refrigerant : R134a

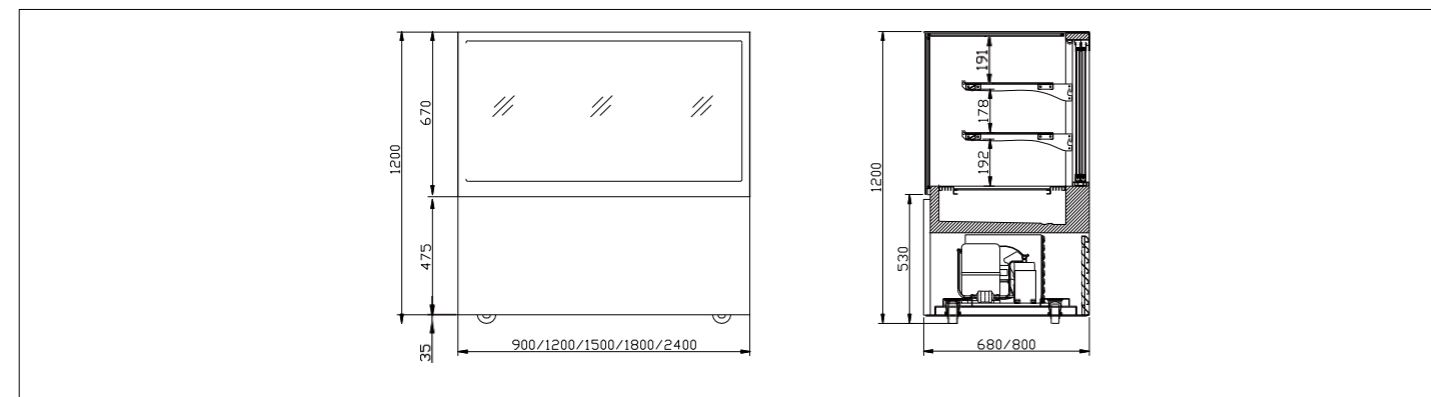

## FLOOR STANDING SHOWCASE REFRIGERATOR

### TECHNICAL DATA



Model	NSR730V	NSR740V	NSR750V	NSR760V	NSR780V	NSR830V	NSR840V	NSR850V	NSR860V	NSR880V
Temp Range	2°C~ 8°C									
Capacity(L)	355	480	605	735	985	435	590	740	890	1200
Rating Power (W)	910	1120	1140	1340	1460	930	1140	1160	1360	1480
Climate Class	4/5/7									
<b>External Dimension (mm)</b>										
Width	900	1200	1500	1800	2400	900	1200	1500	1800	2400
Depth	680					800				
Height	1350					1350				
<b>Packing Size (mm)</b>										
Width	985	1285	1585	1885	2485	985	1285	1585	1885	2485
Depth	765					885				
Height	1500					1500				
<b>Weight (kgs)</b>										
Net Weight	196	239	280	319	361	218	264	307	344	388
Gross Weight	229	279	326	371	426	254	307	356	399	456
Shelves	4									
<b>Refrigerant</b>										
Type	R290									
Door Opening Direction	Back sliding doors (front doors for options)									
<b>Shipping</b>										
Qty/20GP	17	12	10	9	6	12	10	7	6	4
Qty/40HQ	36	27	22	18	12	26	22	15	13	8

Optional Refrigerant : R134a

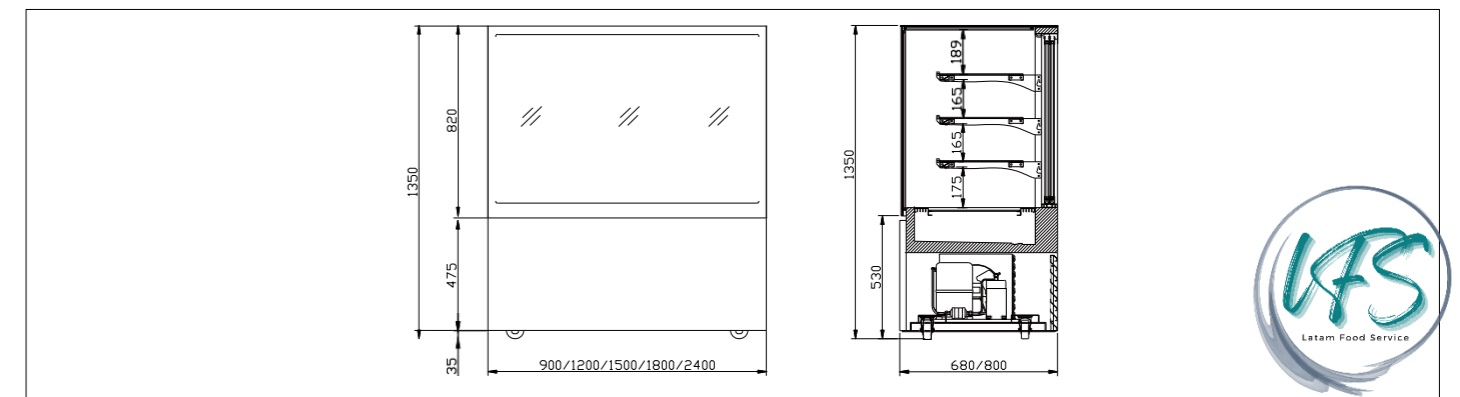



## FLOOR STANDING SHOWCASE REFRIGERATOR

### TECHNICAL DATA

Model	NGR730V	NGR740V	NGR750V	NGR760V	NGR780V	NGR830V	NGR840V	NGR850V	NGR860V	NGR880V
Temp Range	2°C~ 8°C									
Capacity(L)	430	580	730	880	1180	520	700	890	1070	1435
Rating Power(W)	1030	1130	1210	1280	1410	1055	1155	1235	1305	1420
Climate Class	4/5/7									
<b>External Dimension (mm)</b>										
Width	900	1200	1500	1800	2400	900	1200	1500	1800	2400
Depth	680					800				
Height	1500					1500				
<b>Packing Size (mm)</b>										
Width	985	1285	1585	1885	2485	985	1285	1585	1885	2485
Depth	765					885				
Height	1630					1630				
<b>Weight (kgs)</b>										
Net Weight	211	256	298	337	378	235	283	327	364	401
Gross Weight	246	299	347	393	448	273	329	379	423	480
Shelves	4									
<b>Refrigerant</b>										
Type	R134a				R404a	R134a			R404a	
Door Opening Direction	Back sliding doors (front doors for options)									
<b>Shipping</b>										
Qty/20GP	17	12	10	9	6	12	10	7	6	4
Qty/40HQ	36	27	22	18	12	26	22	15	13	8



# FLOOR STANDING SHOWCASE REFRIGERATOR



- Anti-condensation, energy saving and better visual effect
- Improved air cooling system ensuring effective air circulation
- Equipped with both baked castors and adjustable feet
- Automatic defrost function ensuring the evaporator working perfectly
- Automatic vaporizing the defrost water with the heat of discharge pipe of compressor
- Hang type ventilation grill, easy to remove for regular maintenance
- Patented semi frequency conversion technique, using electronic expansion valve with own control system, could adjust the parameter to reach to the optimal working performance automatically and save 30% energy consumption



Warm white or cool white LED lights illumination, perfectly displaying food, avoiding glaring



High quality imported compressor and fan motor, energy saving, lower noise, and longer lifetime



Smart precise digital controller with large LCD display



Improved door track and imported high quality bearing, easily using for sliding doors, smoothly and lower noise



Independent electric board cooling system could be taken out easily for replacement or maintenance

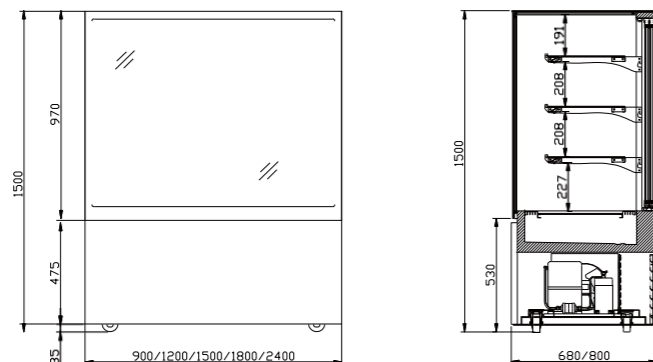



## FLOOR STANDING SHOWCASE REFRIGERATOR

### TECHNICAL DATA

Model <sup>o</sup>	NR730A	NR740A	NR750A	NR7@0A	NR780A	NR830A	NR840A	NR850A	NR8@0A	NR880A
Temp Range	2°C~ 8°C									
Capacity(L)	230	310	390	470	630	350	470	595	715	965
Rating Power	990	1090	1170	1240	1288	990	1090	1170	1240	1288
Climate Class	4/5/7									
<b>External Dimension (mm)</b>										
Width	900	1200	1500	1800	2400	900	1200	1500	1800	2400
Depth	680					800				
Height	1200					1200				
<b>Packing Size (mm)</b>										
Width	990	1285	1585	1885	2485	985	1285	1585	1885	2485
Depth	765					885				
Height	1330					1330				
<b>Weight (kgs)</b>										
Net Weight	163	200	236	270	314	183	220	260	293	330
Gross Weight	193	234	279	319	364	216	260	307	345	392
Shelves	3									
<b>Refrigerant</b>										
Type	R134a				R404a	R134a				R404a
Door Opening Direction	Back sliding door									
<b>Shipping ☒☒☒</b>										
Qty/20GP	17	12	10	9	6	12	10	7	6	4
Qty/40HQ	72	54	44	36	24	52	44	28	24	16

Optional Refrigerant: R290

heating tempered glass

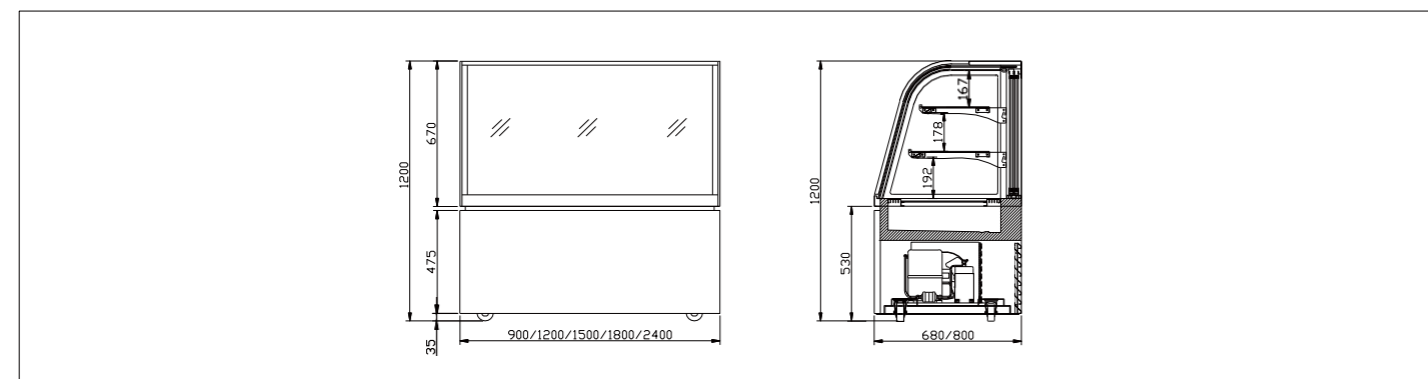

## FLOOR STANDING SHOWCASE REFRIGERATOR

### TECHNICAL DATA



Model	NSR730A	NSR740A	NSR750A	NSR7@0A	NSR780A	NSR830A	NSR840A	NSR850A	NSR8@0A	NSR880A
Temp Range	2°C~ 8°C									
Capacity(L)	280	380	480	580	770	360	480	610	730	990
Rating Power (W)	1030	1130	1210	1280	1328	1030	1130	1210	1280	1328
Climate Class	4/5/7									
<b>External Dimension (mm)</b>										
Width	900	1200	1500	1800	2400	900	1200	1500	1800	2400
Depth	680					800				
Height	1370					1370				
<b>Packing Size (mm)</b>										
Width	985	1285	1585	1885	2485	985	1285	1585	1885	2485
Depth	765					885				
Height	1500					1500				
<b>Weight (kgs)</b>										
Net Weight	186	206	220	300	336	203	250	284	332	363
Gross Weight	219	266	290	375	415	247	294	344	406	430
Shelves	4									
<b>Refrigerant</b>										
Type	R134a				R404a	R134a				R404a
Door Opening Direction	Back sliding door									
<b>Shipping</b>										
Qty/20GP	17	12	10	9	6	12	10	7	6	4
Qty/40HQ	36	27	22	18	12	26	22	14	12	8

Optional Refrigerant: R290

t ITO heating tempered glass 玻

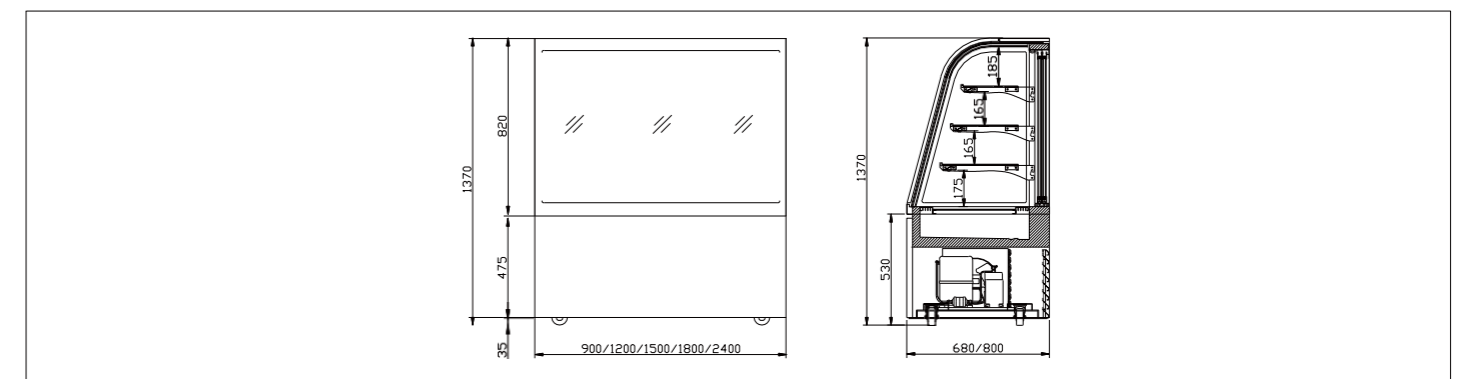



## FLOOR STANDING SHOWCASE REFRIGERATOR

### TECHNICAL DATA



Model	NK730A	NK740A	NK750A	NK7@0A	NK780A	NK830A	NK840A	NK850A	NK8@0A	NK880A
Temp Range	2°C~ 8°C									
Capacity(L)	220	300	370	450	610	280	380	480	580	770
Rating Power (W)	975	1055	1120	1239	1288	975	1055	1120	1239	1288
Climate Class	4/5/7									
<b>External Dimension (mm)</b>										
Width	900	1200	1500	1800	2400	900	1200	1500	1800	2400
Depth	680					800				
Height	1200					1200				
<b>Packing Size (mm)</b>										
Width	985	1285	1585	1885	2485	985	1285	1585	1885	2485
Depth	765					885				
Height	1330					1330				
<b>Weight (kgs)</b>										
Net Weight	163	200	236	270	314	183	220	260	293	330
Gross Weight	193	234	279	319	364	216	260	307	345	392
Shelves	3									
<b>Refrigerant</b>										
Type	R134a			R404a	R134a			R404a		
Door Opening Direction	Back sliding door (front doors for options)									
<b>Shipping</b>										
Qty/20GP	17	12	10	9	6	12	10	7	6	4
Qty/40HQ	72	54	44	36	24	52	44	28	24	16

Optional Refrigerant: R290

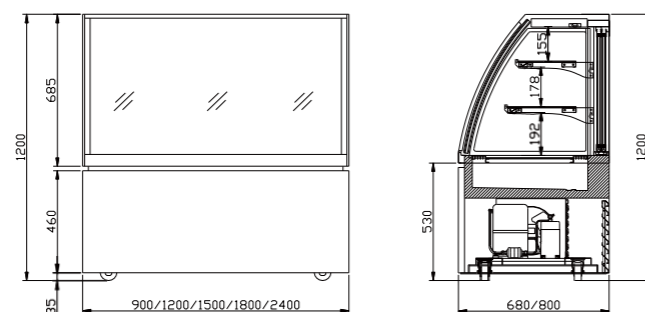

## FLOOR STANDING SHOWCASE REFRIGERATOR

### TECHNICAL DATA



Model	NSK730A	NSK740A	NSK750A	NSK7@0A	NSK780A	NSK830A	NSK840A	NSK850A	NSK8@0A	NSK880A
Temp Range	2°C~ 8°C									
Capacity(L)	300	400	510	610	820	370	510	640	770	1030
Rating Power (W)	995	1085	1155	1220	1288	995	1085	1155	1220	1288
Climate Class	4/5/7									
<b>External Dimension (mm)</b>										
Width	900	1200	1500	1800	2400	900	1200	1500	1800	2400
Depth	680					800				
Height	1370					1370				
<b>Packing Size (mm)</b>										
Width	985	1285	1585	1885	2485	985	1285	1585	1885	2485
Depth	765					885				
Height	1500					1500				
<b>Weight (kgs)</b>										
Net Weight	186	226	263	300	336	208	250	290	324	363
Gross Weight	219	266	310	351	400	244	294	340	379	430
Shelves	4									
<b>Refrigerant</b>										
Type	R134a			R404a	R134a			R404a		
Door Opening Direction	Back sliding door (front doors for options)									
<b>Shipping</b>										
Qty/20GP	17	12	10	9	6	12	10	7	6	4
Qty/40HQ	36	27	22	18	12	26	22	14	12	8

Optional Refrigerant: R290

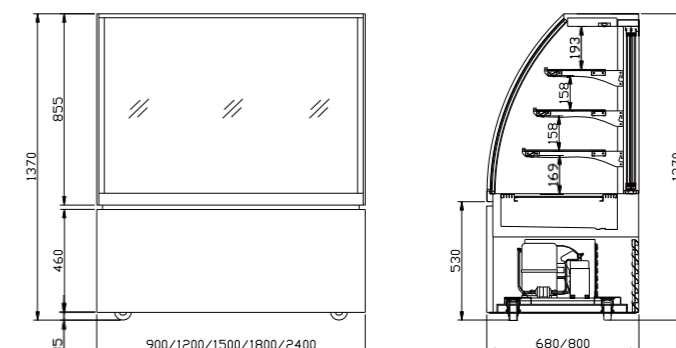



## FLOOR STANDING SHOWCASE REFRIGERATOR

### TECHNICAL DATA



Model	NSG730A	NSG740A	NSG750A	NSG7@0A	NSG780A
Temp Range	2°C~ 8°C				
Capacity(L)	300	410	520	630	840
Rating Power (W)	1030	1130	1210	1280	1427
Climate Class	4/5/7				
<b>External Dimension (mm)</b>					
Width	900	1200	1500	1800	2400
Depth	680				
Height	1370				
<b>Packing Size (mm)</b>					
Width	985	1285	1585	1885	2485
Depth	765				
Height	1500				
<b>Weight (kgs)</b>					
Net Weight	200	240	278	315	350
Gross Weight	230	275	315	360	410
Shelves	4				
<b>Refrigerant</b>					
Type	R134a			R404a	
Door Opening Direction	Back sliding door				
<b>Shipping</b>					
Qty/20GP	17	12	10	9	6
Qty/40HQ	36	27	22	18	12

Optional Refrigerant: R290



ITO heating tempered glass

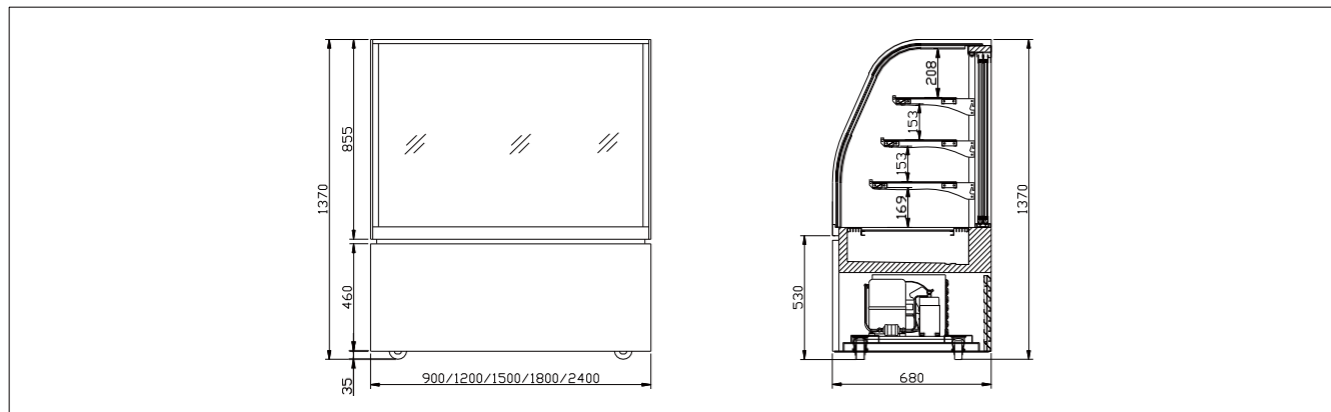

## FLOOR STANDING SHOWCASE REFRIGERATOR

### TECHNICAL DATA



Model	NSG830A	NSG840A	NSG850A	NSG8@0A	NSG880A
Temp Range	2°C~ 8°C				
Capacity(L)	380	520	650	790	1060
Rating Power (W)	1030	1130	1210	1280	1427
Climate Class	4/5/7				
<b>External Dimension (mm)</b>					
Width	900	1200	1500	1800	2400
Depth	800				
Height	1370				
<b>Packing Size (mm)</b>					
Width	985	1285	1585	1885	2485
Depth	885				
Height	1500				
<b>Weight (kgs)</b>					
Net Weight	218	260	300	334	373
Gross Weight	250	294	340	382	433
Shelves	4				
<b>Refrigerant</b>					
Type	R134a			R404a	
Door Opening Direction	Back sliding door				
<b>Shipping</b>					
Qty/20GP	12	10	7	6	4
Qty/40HQ	26	22	14	13	8

Optional Refrigerant: R290



ITO heating tempered glass

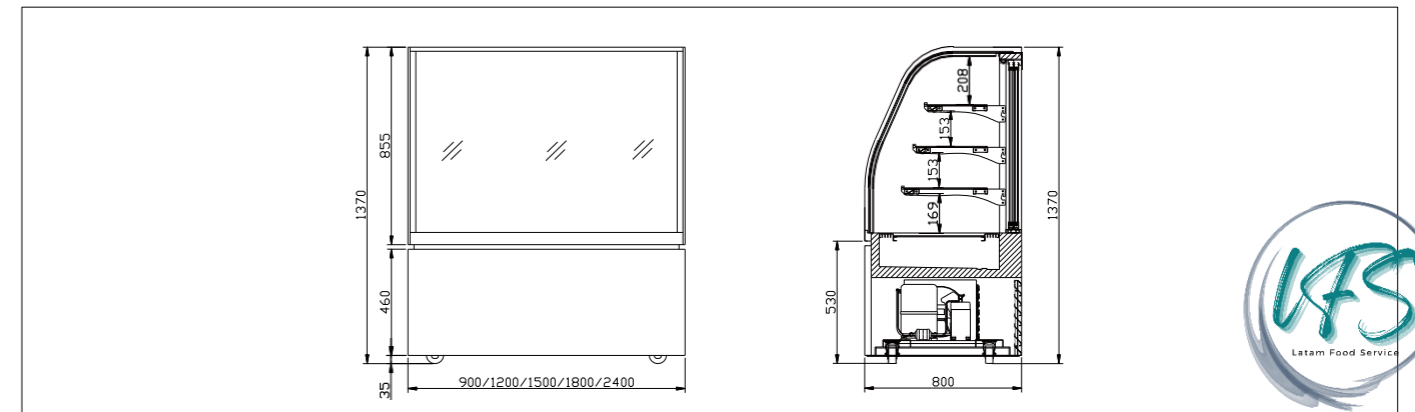



# SHOWCASE REFRIGERATOR WITH DRAWER



P720VT1



P740VT2



E850VT2



Warm white or cool white LED lights illumination, perfectly displaying food, avoiding glaring



High quality imported compressor and fan motor, energy saving, lower noise, and longer lifetime



Smart precise digital controller with large LCD display



Independent electric board cooling system could be taken out easily for replacement or maintenance

## TECHNICAL DATA



Model	P720VT1	P740VT2	E850VT2
Temp Range	2°C~ 8°C		
Capacity(L)	97	194	360
Rating Power (W)	796	1037	830
Climate Class	4/5/7		
<b>External Dimension (mm)</b>			
Width	600	1200	1500
Depth	700		820
Height	1200		
<b>Packing Size (mm)</b>			
Width	685	1285	1585
Depth	785		905
Height	1330		
<b>Weight (kgs)</b>			
Net Weight	119	200	222
Gross Weight	149	238	262
<b>Drawer</b>			
Quantity	1	2	2
<b>Refrigerant</b>			
Type	R290		R134a
<b>Door Opening Direction</b>			
Back drawer			
<b>Shipping</b>			
Qty/20GP	23	11	7
Qty/40HQ	49	24	14

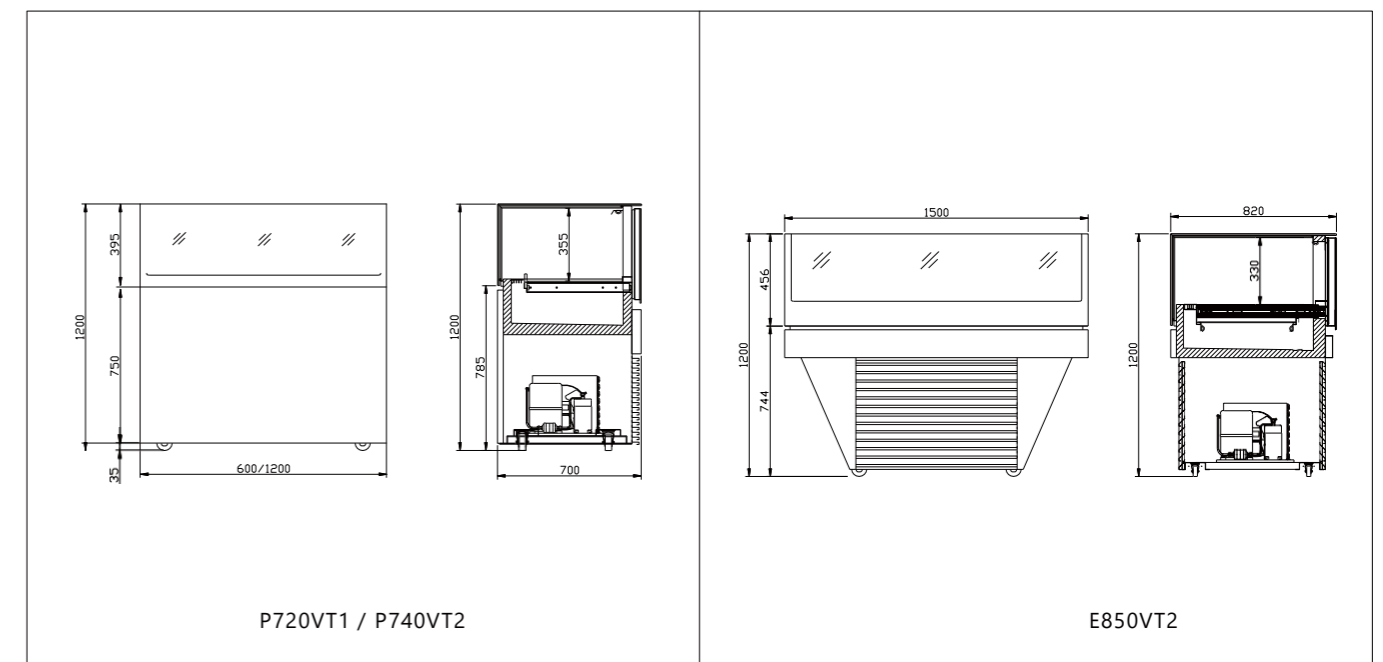



# GELATO SHOWCASE



ICE-100



ICE-120



Warm white or cool white LED lights illumination, perfectly displaying food, avoiding glaring



High quality imported compressor and fan motor, energy saving, lower noise, and longer lifetime



Smart precise digital controller with large LCD display



Improved door track and imported high quality bearing, easily using for sliding doors, smoothly and lower noise



Independent electric board cooling system could be taken out easily for replacement or maintenance

## TECHNICAL DATA

Model	PCE-120-G	PCE-150-G	PCE-180-G	ICE-100	ICE-120
Temp Range	-18°C~ 22°C				
Capacity(L)	52	60	77	43	52
Rating Power (W)	866	978	1118	930	970
Climate Class	A / 5 / 7				
<b>External Dimension (mm)</b>					
Width	1200	1500	1800	1000	1200
Depth	700			640	
Height	1150			1150	
<b>Packing Size (mm)</b>					
Width	1285	1585	1885	1085	1285
Depth	785			725	
Height	1330			1330	
<b>Weight (kgs)</b>					
Net Weight	178	202	230	146	176
Gross Weight	211	265	292	186	209
Display Tray	1/3 GN pan				
Quantity	6	7	9	5	6
Door Opening Direction	Back sliding door				
<b>Refrigerant</b>					
Type	R290	R404A			
<b>Shipping</b>					
Qty/20GP	11	7	7	16	12
Qty/40HQ	24	15	15	34	26

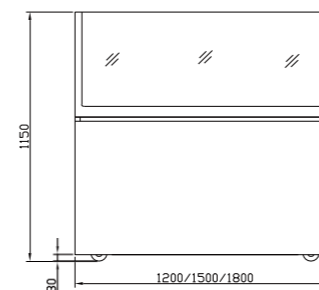

PCE-120-G / PCE-150-G / PCE-180-G

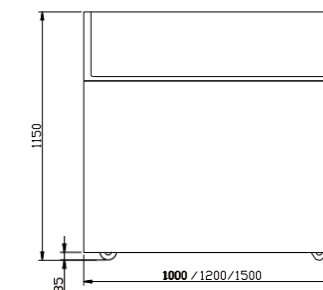
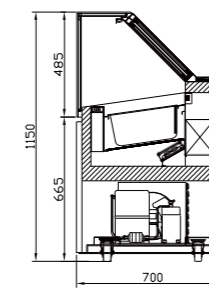

ICE-100 / ICE-120

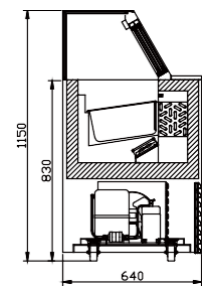





# COUNTERTOP SHOWCASE REFRIGERATOR & WARMER



- Environment-friendly CFC-free Refrigerant R134a or R290
- Voltage and frequency upon request
- Automatic defrosting ensures the evaporator working to its optimum performance
- Warmer or refrigerator upon request



Double glazed safety glass with heater inside is suitable for all climates anti condensation



High quality imported compressor, energy saving, lower noise, and longer lifetime



Smart precise digital controller with large LCD display



Forced air cooling system ensures effective air circulation



Automatic defrosting ensures the evaporator working to its optimum performance. Automatically vaporizing the defrosted water



## COUNTERTOP SHOWCASE REFRIGERATOR & WARMER

### TECHNICAL DATA

Model	NM530A	NM540A	NM550A	H-NM530A	H-NM540A	H-NM550A
Temp Range	2°C~ 8°C			65°C		
Capacity(L)	128	173	218	128	173	218
Rating Power (W)	560	640	710	757	797	837
Climate Class	4/5/7					
<b>External Dimension (mm)</b>						
Width	840	1140	1440	840	1140	1440
Depth	540					
Height	820					
<b>Packing Size (mm)</b>						
Width	950	1250	1550	950	1250	1550
Depth	645					
Height	1045					
<b>Weight (kgs)</b>						
Net Weight	93	106	123	68	89	107
Gross Weight	124	125	145	85	107	128
<b>Shelves</b>						
Quantity	2					
Door Opening Direction	Back sliding doors					
Shelf Material	Stainless Steel			Wire shelf		
<b>Refrigerant</b>						
Type	R290	R290	R290	/	/	/
<b>Shipping</b>						
Qty/20GP	48	34	26	48	34	26
Qty/40HQ	96	72	58	96	72	58

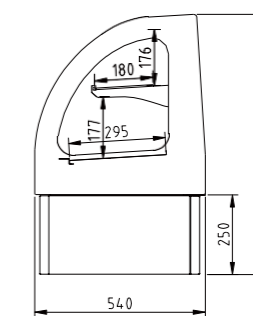
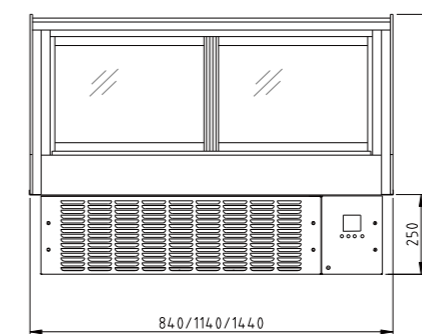



## COUNTERTOP SHOWCASE REFRIGERATOR & WARMER

### TECHNICAL DATA

Model	NGA530V	NGA540V	NGA550V	H-NGA530V	H-NGA540V	H-NGA550V
Temp Range	2°C~ 8°C			65°C		
Capacity(L)	192	260	330	190	260	330
Rating Power (W)	527	673	716	814	874	934
Climate Class	4/5/7					
<b>External Dimension (mm)</b>						
Width	900	1200	1500	900	1200	1500
Depth	540					
Height	970					
<b>Packing Size (mm)</b>						
Width	985	1285	1585	985	1285	1585
Depth	625					
Height	1120					
<b>Weight (kgs)</b>						
Net Weight	126	134	158	98	126	154
Gross Weight	159	198	236	121	152	179
<b>Shelves</b>						
Quantity	3					
Door Opening Direction	Back sliding doors (front doors for options)					
Shelf Material	Stainless Steel			Wire shelf		
<b>Refrigerant</b>						
Type	R290	R290	R290	/	/	/
<b>Shipping</b>						
Qty/20GP	48	34	26	48	34	26
Qty/40HQ	96	72	58	96	72	58

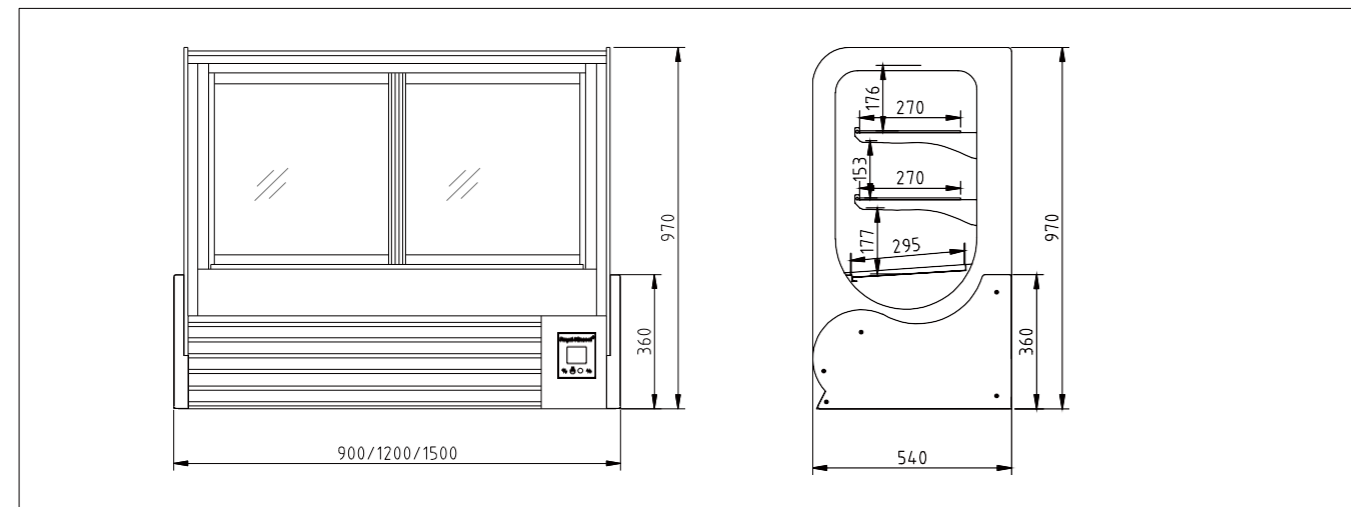

## COUNTERTOP SHOWCASE REFRIGERATOR & WARMER

### TECHNICAL DATA

Model	NS530A	NS540A	NS550A	H-NS530A	H-NS540A	H-NS550A
Temp Range	2°C~ 8°C			65°C		
Capacity(L)	115	155	200	115	155	200
Rating Power (W)	424	529	634	757	797	837
Climate Class	4/5/7					
<b>External Dimension (mm)</b>						
Width	900	1200	1500	900	1200	1500
Depth	540					
Height	820					
<b>Packing Size (mm)</b>						
Width	985	1285	1585	985	1285	1585
Depth	625					
Height	970					
<b>Weight (kgs)</b>						
Net Weight	105	125	145	85	105	125
Gross Weight	120	145	165	100	125	145
<b>Shelves</b>						
Quantity	2					
Door Opening Direction	Back sliding doors (front doors for options)					
Shelf Material	Stainless Steel			Wire shelf		
<b>Refrigerant</b>						
Type	R290	R290	R290	/	/	/
<b>Shipping</b>						
Qty/20GP	48	34	26	48	34	26
Qty/40HQ	96	72	58	96	72	58

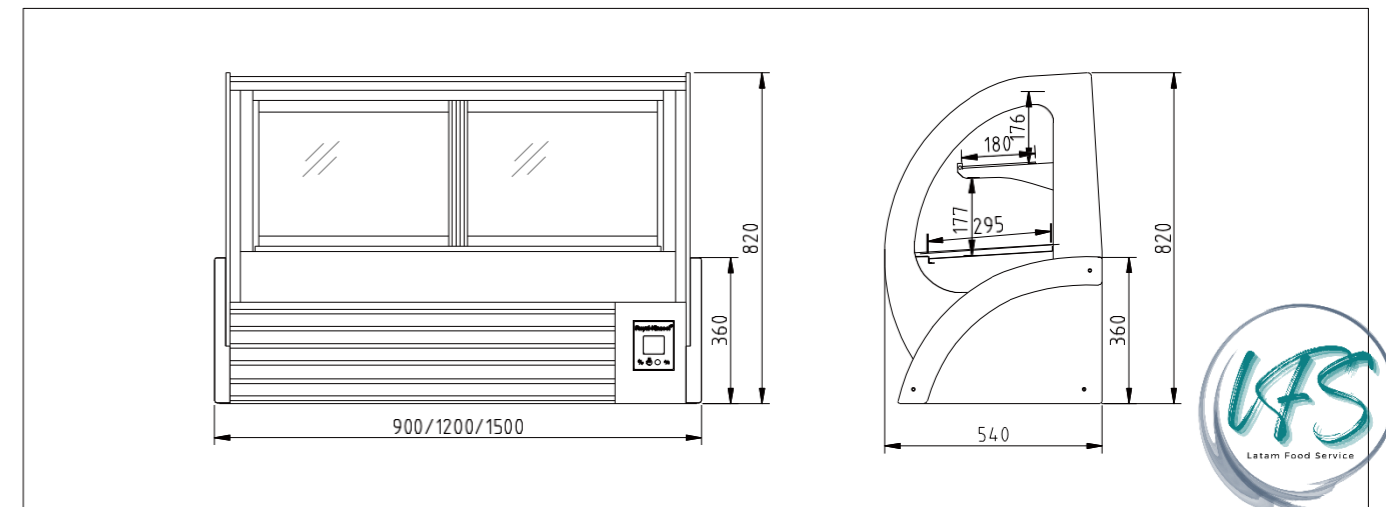



## COUNTERTOP SHOWCASE REFRIGERATOR & WARMER



### TECHNICAL DATA

Model	NA530V	NA540V	NA550V	H-NA530V	H-NA540V	H-NA550V
Temp Range	2°C~ 8°C			65°C		
Capacity(L)	140	190	240	140	190	240
Rating Power (W)	439	544	649	757	797	837
Climate Class	4/5/7					
<b>External Dimension (mm)</b>						
Width	900	1200	1500	900	1200	1500
Depth	540					
Height	820					
<b>Packing Size (mm)</b>						
Width	985	1285	1585	985	1285	1585
Depth	625					
Height	970					
<b>Weight (kgs)</b>						
Net Weight	112	132	155	90	110	130
Gross Weight	129	150	172	109	130	152
<b>Shelves</b>						
Quantity	2					
Door Opening Direction	back sliding doors					
Shelf Material	Stainless Steel			Wire shelf		
<b>Refrigerant</b>						
Type	R290	R290	R290	/	/	/
<b>Shipping</b>						
Qty/20GP	48	34	26	48	34	26
Qty/40HQ	96	72	58	96	72	58

WIREFRAMES ☒ ☒ ☒

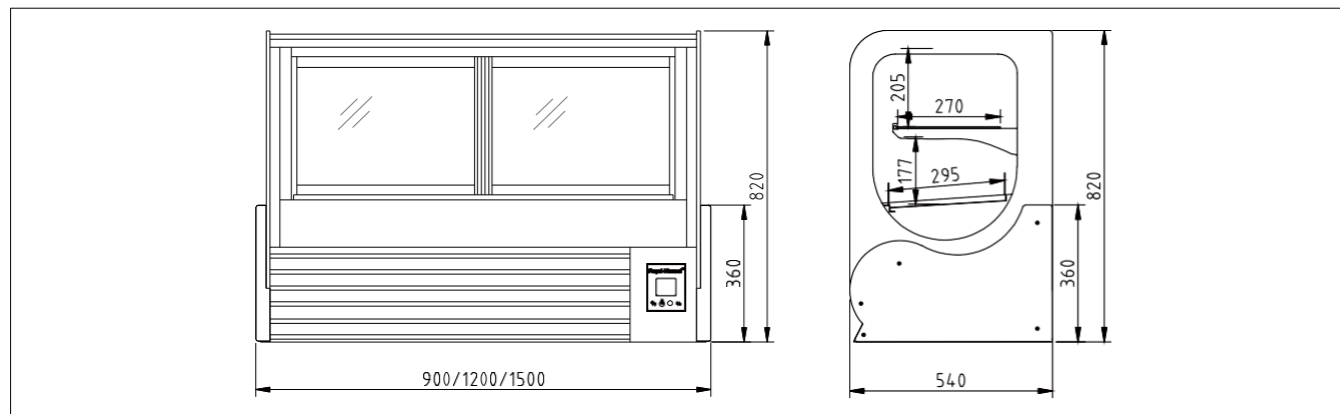



# COUNTERTOP SHOWCASE FREEZER



R404a | R290

Environment-friendly CFC-free Refrigerant R404a or R290



High quality imported compressor, energy saving, lower noise, and longer lifetime



Smart precise digital controller with large LCD display



Forced air cooling system ensures effective air circulation



Hot gas defrost system ensures the evaporator working to its optimum performance. Automatically vaporizing the defrosted water

## TECHNICAL DATA



Model <sup>o</sup>	F-A530V	F-A540V	F-A550V
Temp Range	-12°C~ 18°C		
Capacity (L)	140	190	240
Rating Power (W)	375	623	676
Climate Class	4		
<b>External Dimension (mm)</b>			
Width	900	1200	1500
Depth	540		
Height	790		
<b>Packing Size (mm)</b>			
Width	985	1285	1585
Depth	625		
Height	980		
<b>Weight (kgs)</b>			
Net Weight	108	130	152
Gross Weight	125	151	177
<b>PC pan PC</b>			
Quantity	4	5	7
Size	325*179*100	325*179*100	325*179*100
<b>Refrigerant</b>			
Type	R404a	R404a	R404a
Door Opening Direction	Back sliding door		
<b>Shipping</b>			
Qty/20GP	48	34	26
Qty/40HQ	96	72	58

Optional Refrigerant: R290

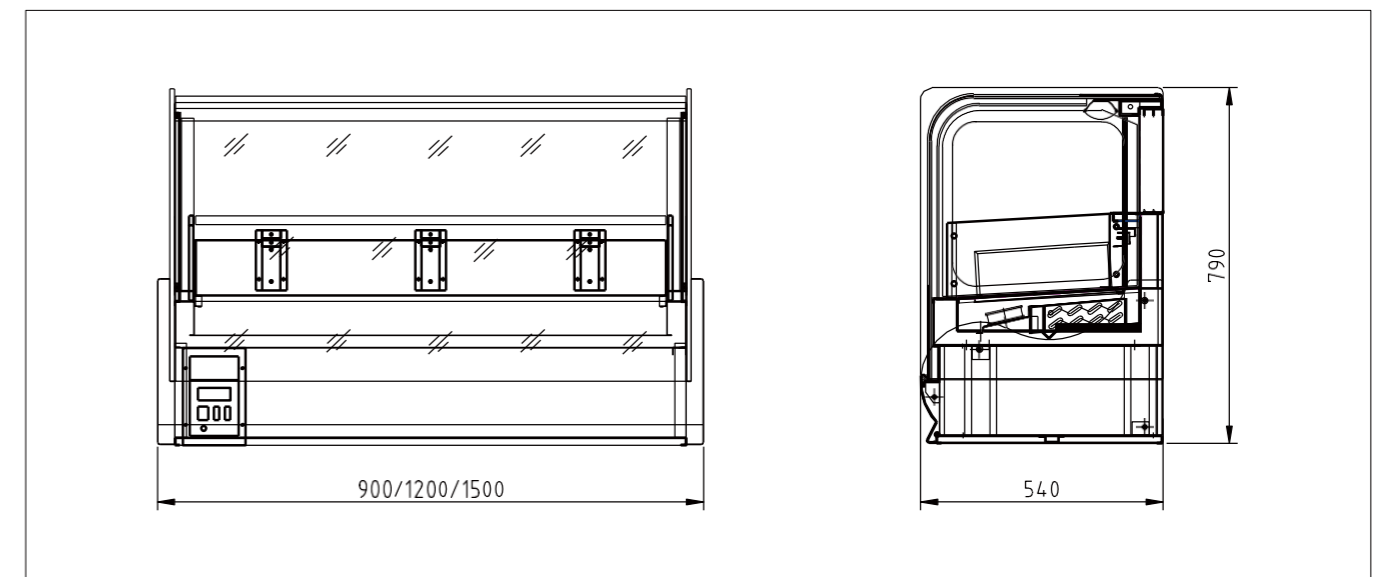



# SUSHI BAR COLLECTION

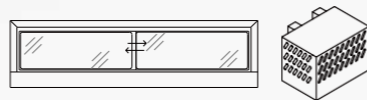

Remote condensation unit, external drainage is required



Warm white or cool white LED lights illumination, perfectly displaying food, avoiding glaring



45° joint for top and front glass, good visual effect

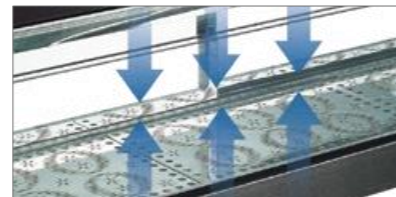

Both copper pipe on the top and bottom, cooling fast and evenly



High quality imported compressor, energy saving, lower noise, and longer lifetime



Removable stainless steel shel, feasy to clean



Smart precise digital controller with large LCD display and cabinet temperature display. Separated high quality metal light switch



## TECHNICAL DATA

Model	SUSHI-R100	SUSHI-R120	SUSHI-R150	SUSHI-R180
Temp Range	4°C~ 8°C			
Capacity (L)	50	60	75	90
Rating Power (W)	366	425	433	441
Climate Class	3			
<b>External Dimension (mm)</b>				
Width	1000	1200	1500	1800
Depth	350			
Height	325			
<b>Packing Size (mm)</b>				
Width	1050+690	1250+690	1550+690	1850+690
Depth	450+480			
Height	600+620			
<b>Weight (kgs)</b>				
Net Weight	36+27	44+27	64+27	74+27
Gross Weight	56+45	71+45	88+45	106+45
<b>Refrigerant</b>				
Type	R134a			
<b>Shipping</b>				
Qty/20GP	45	42	36	30
Qty/40HQ	96	84	75	66

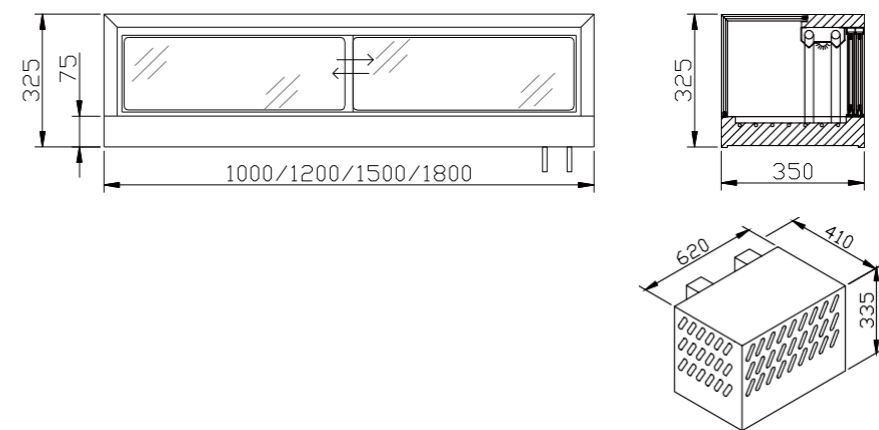



# Upright Chiller & Freezer Collection



LFSUSA.STORE



# UPRIGHT CHILLER & FREEZER COLLECTION

## GENERAL FEATURES

- GN pan designed
- High density 75mm thick insulation foam with zero ODP ( Ozone Depletion Potential ) and low GWP ( Global Warming Potential )
- Over 90 degree door opening allows easy placing and stock checking
- Environmental-friendly CFC-free refrigerant (R134a/R404a/R290)
- Designed and engineered to operate at the temperature range from -10 to 43 °C
- 304 stainless steel exterior and interior finish, provides high corrosion resistance properties, ensuring food safety standard
- Self-developed controlling system can examine the faulty automatically, and display the relative codes on the digital controller, which makes the maintenance much easier and more effective
- Hot gas defrost system ensures the evaporator working to its optimum performance
- Automatically vaporizing defrost water, drainage is not required
- Audible and visual Er4, door opening (over 3 minutes) alarm for freezer ensures food quality and minimises energy consumption



● Adjustable anti-tilt trayslides, match GN design

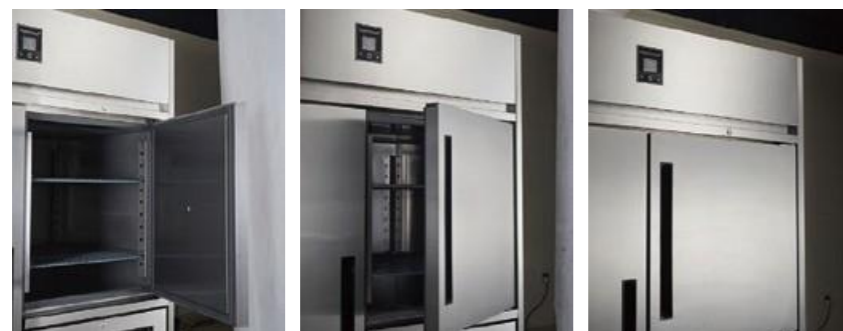

● Self-closing doors design prevents heat ingress and reduces energy consumption



● Top-mounted cooling system with hidden evaporator, maximises the internal capacity and maintains easily



● One half door can be changed to two drawers if requested. The track is Complex stainless steel bimodal track, allowing loading capacity 50 kgs



● Patented semi frequency variable technique using electronic expansion valve controlled by VFD(variable frequency drive), can automatically adjust the operating parameters, ensuring wonderful working performance and lower energy consumption

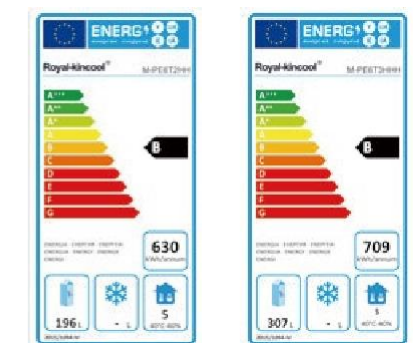

● ROYAL-KINCOOL reach-in refrigerators obtain the European energy efficiency labels and the best rank to Class B. Comparing to some international brands in the industry, ROYAL-KINCOOL reach-in refrigerators reached to the same level, even better in partial products



● Patented top-mounted removable independently cooling system, can be replaced with new one immediately as a whole. Interchangeable cooling system with different temperature ranges allows flexible application and easy maintenance



● Forced air cooling system ensures effective air circulation, reaching to the setting temperature within 2 hours (Empty)



● The evaporator fan motor stops once the door opens to reduce energy consumption (Freezer only)



● Round corners design, easy for cleaning



● Optional heating glass door. Anti-condensation and clear visibility



● Adjustable feet or castors upon request



● Removable door frame cover, easy to replace the heaters inside

● Accommodating 2/1 GN size

● Galvanized sheet exterior back and base

● Foodsafe 304 grade stainless steel exterior and interior

● Fitted with cylindrical lock for doors

## OPTIONS

- 304 grade stainless steel exterior and interior back / base
- Heated film glass door
- Pass through door
- 2 or 3 drawers can be replaced for the low half section
- Cylindrical lock for drawers
- Internal light for door type
- Castors or adjustable feet
- Additional shelves/ trayslides/ E shape trayslides

## PRODUCT LIST

8U1G



8U1F



8U1HN



8U1DD



8U1HH



8U2FHH



8U2GG



8U2FF



8U2HNHN



8U2DDDD



8U2HHHH





## UPRIGHT CHILLER & FREEZER

### TECHNICAL DATA



Model	M-PW8UIF	M-PW8U1HH	M-PW8U1HN	M-PW8U1G	M-PW8U1DD
Temp Range	-2°C ~ 4°C				
Capacity(L) ☒U	550				
Rating Power (W) ⚡	480		530		
Climate Class 🌡️	4/5/7				
<b>External Dimension (mm)</b>					
Width	737				
Depth	815				
Height	1980				
<b>Internal Dimension (mm)</b>					
Width	587				
Depth	683				
Height	1370				
<b>Thickness of 304 Grade Stainless Steel (mm)</b>					
Exterior	0.7				
Interior	0.5				
Door or Drawer	0.7				
<b>Open Depth (mm)</b>					
Door Type	1435				
Drawer Type	1525				
<b>Maximum loading Height of Drawer (mm Per Drawer)</b>					
2 Drawers	100				
3 Drawers	150				
Compressor (HP)	1/4				
<b>Refrigerant</b>					
Type	R134a				
<b>Standard Fitting for Door Type</b>					
PE Coated Shelf	3	2	3		
Trayslides (Pair)	3	2	3		
Packing	Simple package/Carton				
Packing Size	777*855*2030mm				
<b>Shipping</b>					
Qty/20GP	14				
Qty/40HQ	28				

Optional Refrigerant: R290



### TECHNICAL DATA



## UPRIGHT CHILLER & FREEZER

Model	L-PW8UIF	L-PW8U1HH	L-PW8U1HN	L-PW8U1G	L-PW8U1DD
Temp Range	-18°C ~ 22°		-14°C ~ 18°		
Capacity(L)	550				
Rating Power (W) ⚡	690		760		
Climate Class	4/5/7				
<b>External Dimension (mm)</b>					
Width	737				
Depth	815				
Height	1980				
<b>Internal Dimension (mm)</b>					
Width	587				
Depth	683				
Height	1370				
<b>Thickness of 304 Grade Stainless Steel (mm) #304</b>					
Exterior	0.7				
Interior	0.5				
Door or Drawer	0.7				
<b>Open Depth (mm)</b>					
Door Type	1435				
Drawer Type	1525				
<b>Maximum loading Height of Drawer (mm Per Drawer)</b>					
2 Drawers	100				
3 Drawers	150				
Compressor (HP)	3/4				
<b>Refrigerant</b>					
Type	R134a				
<b>Standard Fitting for Door Type</b>					
PE Coated Shelves	3	2	3		
Trayslides (Pair)	3	2	3		
Packing	Simple package/Carton				
Packing Size	777*855*2030mm				
<b>Shipping</b>					
Qty/20GP	14				
Qty/40HQ	28				

Optional Refrigerant: R290



## UPRIGHT CHILLER & FREEZER



### TECHNICAL DATA



Model	M-PW8U 2HHH	M-PW8U 2FF	M-PW8U 2FHH	M-PW8U 2HNHN	L-PW8U 2HHH	L-PW8U 2FF	L-PW8U 2FHH	L-PW8U 2HNHN
Temp Range	-2°C ~ 4°C				-18°C ~ 22°			
Capacity(L)	1170							
Rating Power (W)	520				950			
Climate Class	4/5/7							
<b>External Dimension (mm)</b>								
Width	1400							
Depth	815							
Height	1980							
<b>Internal Dimension (mm)</b>								
Width	1250							
Depth	683							
Height	1384							
<b>Thickness of 304 Grade Stainless Steel (mm) #304</b>								
Exterior	0.7							
Interior	0.5							
Door or Drawer	0.7							
<b>Open Depth (mm)</b>								
Door Type	1435							
Drawer Type	1525							
<b>Maximum Loading Height of Drawer (mm per drawer)</b>								
2 Drawers	150							
3 Drawers	100							
Compressor (HP)	3/8				1			
<b>Refrigerant</b>								
Type	R134a				R404a			
<b>Standard Fitting for Door Type</b>								
PE Coated Shelves	6	4	6	4	6	4	6	4
Trayslides (Pair)	6	4	6	4	6	4	6	4
Packing	Simple package/Carton							
Packing Size	1440*855*2030mm							
<b>Shipping</b>								
Qty/20GP	8							
Qty/40HQ	16							

Optional Refrigerant: R290



### TECHNICAL DATA



## UPRIGHT CHILLER & FREEZER



Model	M-PW8U2DDDD	M-PW8U2GG	M-PW8U2GDD	L-PW8U2DDDD	L-PW8U2GG	L-PW8U2GDD
Temp Range	-2°C ~ 4°C			-14? ~ -18?		
Capacity(L)	1170					
Rating Power (W)	590			1000		
Climate Class	4/5/7					
<b>External Dimension (mm)</b>						
Width	1400					
Depth	815					
Height	1980					
<b>Internal Dimension (mm)</b>						
Width	1250					
Depth	683					
Height	1384					
<b>Thickness of 304 Grade Stainless Steel (mm)</b>						
Exterior	0.7					
Interior	0.5					
Door or Drawer	0.7					
<b>Open Depth (mm)</b>						
Door Type	1435					
Drawer Type	1525					
<b>Maximum Loading Height of Drawer (mm per drawer)</b>						
2 Drawers	150					
3 Drawers	100					
Compressor (HP)	3/8			1		
<b>Refrigerant</b>						
Type	R134a			R404a		
<b>Standard Fitting for Door Type</b>						
PE Coated Shelves	6					
Trayslides (Pair)	6					
Packing	Simple package/Carton					
Packing Size	1440*855*2030mm					
<b>Shipping</b>						
Qty/20GP	8					
Qty/40HQ	16					

Optional Refrigerant: R290



# UPRIGHT CHILLER&FREEZER (PASS THROUGH TYPE)



## KEY FEATURES

- Patented top-mounted removable independently cooling system, can be replaced with new one immediately as a whole. Interchangeable cooling system with different temperature ranges allows flexible application and easy maintenance
- Patented semi frequency variable technique using electronic expansion valve controlled by VFD (variable frequency drive), can automatically adjust the operating parameters, ensuring wonderful working performance and lower energy consumption
- Adjustable feet or castors upon request.
- Removable door gasket, easy to replace the heaters inside
- Automatically vaporizing defrost water, drainage is not required
- With doors at back and front . more convenient

- Accommodating 2/1 GN size
- Foodsafe 304 grade stainless steel exterior and interior
- Galvanized sheet exterior base
- Fitted with cylindrical lock for doors

## OPTIONS

- 304 grade stainless steel exterior and interior back / base
- Heated film glass door
- Pass through door
- 2 or 3 drawers can be replace for the low half section
- Cylindrical lock for drawers
- Internal light for door type
- Castors or adjustable feet
- Additional shelving / trayslides

## PRODUCT LIST

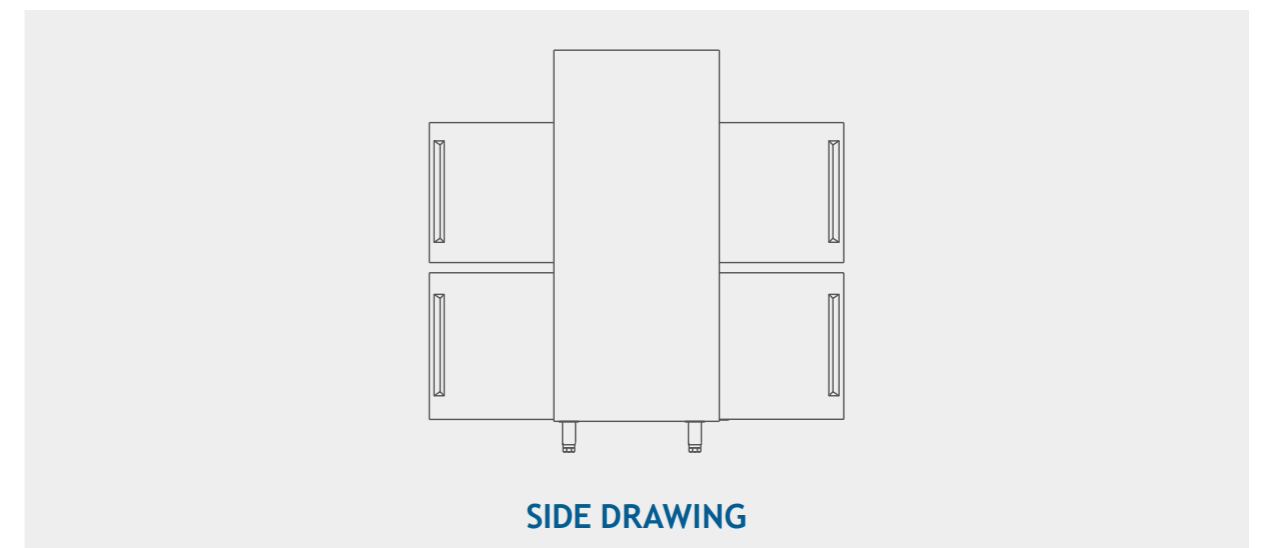

## UPRIGHT CHILLER&FREEZER (PASS THROUGH TYPE)

### TECHNICAL DATA



Model	M-PW8U1F-P	L-PW8U1F-P	M-PW8U1HH-P	L-PW8U1HH-P
Temp Range $\text{°C}$	-2°C ~ 4°C	-18°C ~ 22°C	-2°C ~ 4°C	-18°C ~ 22°C
Capacity(L) $\text{U}$	600			
Rating Power (W) $\text{U}$	430	660	430	660
Climate Class $\text{U}$	4/5/7			
<b>External Dimension (mm)</b>				
Width	737			
Depth	815			
Height	1980			
<b>Internal Dimension (mm)</b>				
Width	587			
Depth	701			
Height	1384			
<b>Thickness of 304 Grade Stainless Steel (mm) 钢</b>				
Exterior	0.7			
Interior	0.5			
Door or Drawer	0.7			
<b>Open Depth (mm)</b>				
Door Type	2040			
Compressor (HP)	1/4	3/4	1/4	3/4
<b>Refrigerant</b>				
Type	R134a	R404a	R134a	R404a
<b>Standard Fitting for Door Type</b>				
PE Coated Shelves	3			
Trayslides (Pair)	3			
Packing	Simple package/Carton			
Packing Size	777*855*2030			
<b>Shipping</b>				
Qty/20GP	14			
Qty/40HQ	28			

Optional Refrigerant: R290



### TECHNICAL DATA



## UPRIGHT CHILLER&FREEZER (PASS THROUGH TYPE)

Model	M-PW8U2HHHH-P	L-PW8U2HHHH-P	M-PW8U2FF-P	L-PW8U2FF-P
Temp Range	-2°C ~ 4°C	-18°C ~ -22°C	-2°C ~ 4°C	-14°C ~ -18°C
Capacity(L)	1400			
Rating Power	460	830	460	830
Climate Class	4/5/7			
<b>External Dimension (mm)</b>				
Width	1400			
Depth	815			
Height	1980			
<b>Internal Dimension (mm)</b>				
Width	1250			
Depth	701			
Height	1384			
<b>Thickness of 304 Grade Stainless Steel (mm)</b>				
Exterior	0.5			
Interior	0.5			
Door or Drawer	0.7			
<b>Open Depth (mm)</b>				
Door Type	2040			
Compressor (HP)	3/8	1	3/8	1
<b>Refrigerant</b>				
Type	R134a	R404a	R134a	R404a
<b>Standard Fitting for Door Type</b>				
PE Coated Shelves	6			
Trayslides (Pair)	6			
Packing	Simple package/Carton			
Packing Size	1440*855*2030			
<b>Shipping</b>				
Qty/20GP	8			
Qty/40HQ	16			

Optional Refrigerant: R290

# UPRIGHT CHILLER & FREEZER (ROLL IN)



## KEY FEATURES

- Patented top-mounted removable independently cooling system, can be replaced with new one immediately as a whole. Interchangeable cooling system with different temperature ranges allows flexible application and easy maintenance
- Patented semi frequency variable technique using electronic expansion valve controlled by VFD (variable frequency drive), can automatically adjust the operating parameters, ensuring wonderful working performance and lower energy consumption
- With door frame heater
- Automatically vaporizing defrost water, drainage is not required
- European GN design, available for 2/1 GN pan, 1/1 GN pan or 600\*400 bakery tray

● Foodsafe 304 grade stainless steel exterior and interior

● Galvanized sheet exterior back and base

## OPTIONS

● 304 grade stainless steel exterior and interior back /base

● Lock plate



## UPRIGHT CHILLER & FREEZER (ROLL IN)

### TECHNICAL DATA



Model	M-PW9U1F-T	L-PW9U1F-T	M-PW9U2FF-T	L-PW9U2FF-T
Temp Range	-2°C ~ 4°C	-18°C ~ -22°C	-2°C ~ 4°C	-18°C ~ -22°C
Capacity (L)	1300		2700	
Rating Power (W)	460	827	598	1075
Climate Class	4/5/7			
<b>External Dimension (mm)</b>				
Width	900		1850	
Depth	980			
Height	2380			
<b>Internal Dimension (mm)</b>				
Width	750		1695	
Depth	856			
Height	1980			
<b>Thickness of 304 Grade Stainless Steel (mm)</b>				
Exterior	0.7			
Interior	0.5			
Door or Drawer	0.7			
<b>Open Depth (mm)</b>				
Door Type fl	1760			
<b>Compressor (HP)</b>				
	3/8	1	1/2	1.5
<b>Refrigerant</b>				
Type	R134a	R404a	R134a	R404a
Weight (g)	500	700	650	910
<b>Packing</b>				
	Polywood Case			
Packing Size	965*1042*2645		1910*1042*2645	

Optional Refrigerant: R290

# UPRIGHT CHILLER&FREEZER WITH BAKERY TRAYS

## KEY FEATURES



● Suitable for 600\*400 bakery tray

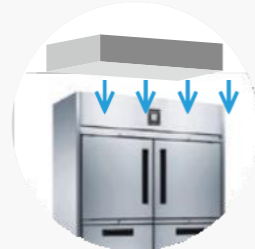

● Patented top-mounted removable independently cooling system, can be replaced with new one immediately as a whole. Interchangeable cooling system with different temperature ranges allows flexible application and easy maintenance



● Patented semi frequency variable technique using electronic expansion valve controlled by VFD (variable frequency drive), can automatically adjust the operating parameters, ensuring wonderful working performance and lower energy consumption



● Removable door gasket, easy to replace the heaters inside



● Adjustable feet or castors upon request



● Automatically vaporizing defrost water, drainage is not required

● Accommodating 2/1 GN size

● Foodsafe 304 grade stainless steel exterior and interior

● Galvanized sheet exterior back and base

● Fitted with cylindrical lock for doors

## OPTIONS

- 304 grade stainless steel exterior and interior back /base
- Heated film glass door
- Pass through door
- 2 or 3 drawers can be replace for the low half section
- Cylindrical lock for drawers
- Internal light for door type
- Castors or adjustable feet
- Accommodate 400\*600mm size
- Additional shelving / trayslides



## TECHNICAL DATA

Model	F-PW8U1F	F-PW8U2FF
Temp Range	-18°C ~-22°C	-18°C ~-22°C
Capacity(L)	600	1400
Rating Power	690	800
Climate Class	4/5/7	
<b>External Dimension (mm)</b>		
Width	737	1400
Depth	815	
Height	1980	
<b>Internal Dimension (mm)</b>		
Width	587	
Depth	683	
Height	1370	
<b>Thickness of 304 Grade Stainless Steel (mm)</b>		
Exterior	0.7	
Interior	0.5	
Door or Drawer	0.7	
<b>Open Depth (mm)</b>		
Door Type fl	1435	
Compressor (HP)	3/4	1
<b>Refrigerant</b>		
Type	R404a	R404a
<b>Standard Fitting for Door Type</b>		
Quantity of Bakery Trays	13	26
Size of Bakery Trays (mm)	600*400	
Packing	Simple package/Carton	
Packing Size	777*855*2030mm	1440*855*2030mm
<b>Shipping</b>		
Qty/20GP	14	10
Qty/40HQ	30	21

Optional Refrigerant: R290



Counter Chiller  
& Freezer  
Collection



LFSUSA.STORE

# COUNTER CHILLER & FREEZER COLLECTION

## GENERAL FEATURES

- GN pan designed
- High density 75mm thick insulation foam with zero ODP (Ozone Depletion Potential) and low GWP (Global Warming Potential)
- Over 90 degree door opening allows easy loading and stock checking
- Environmental-friendly CFC-free refrigerant (R134a/R404a/R290)
- Designed and engineered to operate at the ambient temp 43+ .
- 304 stainless steel exterior and interior finish, provides high corrosion resistance properties, ensuring food safety standard
- Self-developed controlling system can examine the faulty automatically, and display the relative codes on the digital controller, which makes the maintenance much easier and more effective
- Hot gas defrost ensures the evaporator working to its optimum performance.
- Automatically vaporizing defrost water, drainage is not required.
- Audible and visual Er4, door opening (over 3 minutes) alarm for freezer ensures food quality and minimises energy consumption
- Optional I/O glass door. Anti-condensation and clear visibility
- The whole cooling system is independent and removable, saving space.



- Adjustable anti-tilt trayslides, matching GN design



- Forced air cooling system ensures effective air circulation.



- One half door can be changed to two drawers if requested. The track is Complex stainless steel bimodal track, allowing loading capacity 50 kgs



- Patented semi frequency variable technique using electronic expansion valve controlled by VFD(variable frequency drive), can automatically adjust the operating parameters, ensuring wonderful working performance and lower energy consumption



- Patented top-mounted removable independently cooling system, can be replaced with new one immediately as a whole. Interchangeable cooling system with different temperature ranges allows flexible application and easy maintenance



- Round corners design, easy for cleaning



- Removable door gasket, easy to replace the heaters inside



- Adjustable feet or castors upon request



- Self-closing doors design prevents heat ingress and reduces energy consumption



- The evaporator fan motor stops once the door opens to reduce energy consumption (Freezer only)



## KEY FEATURES

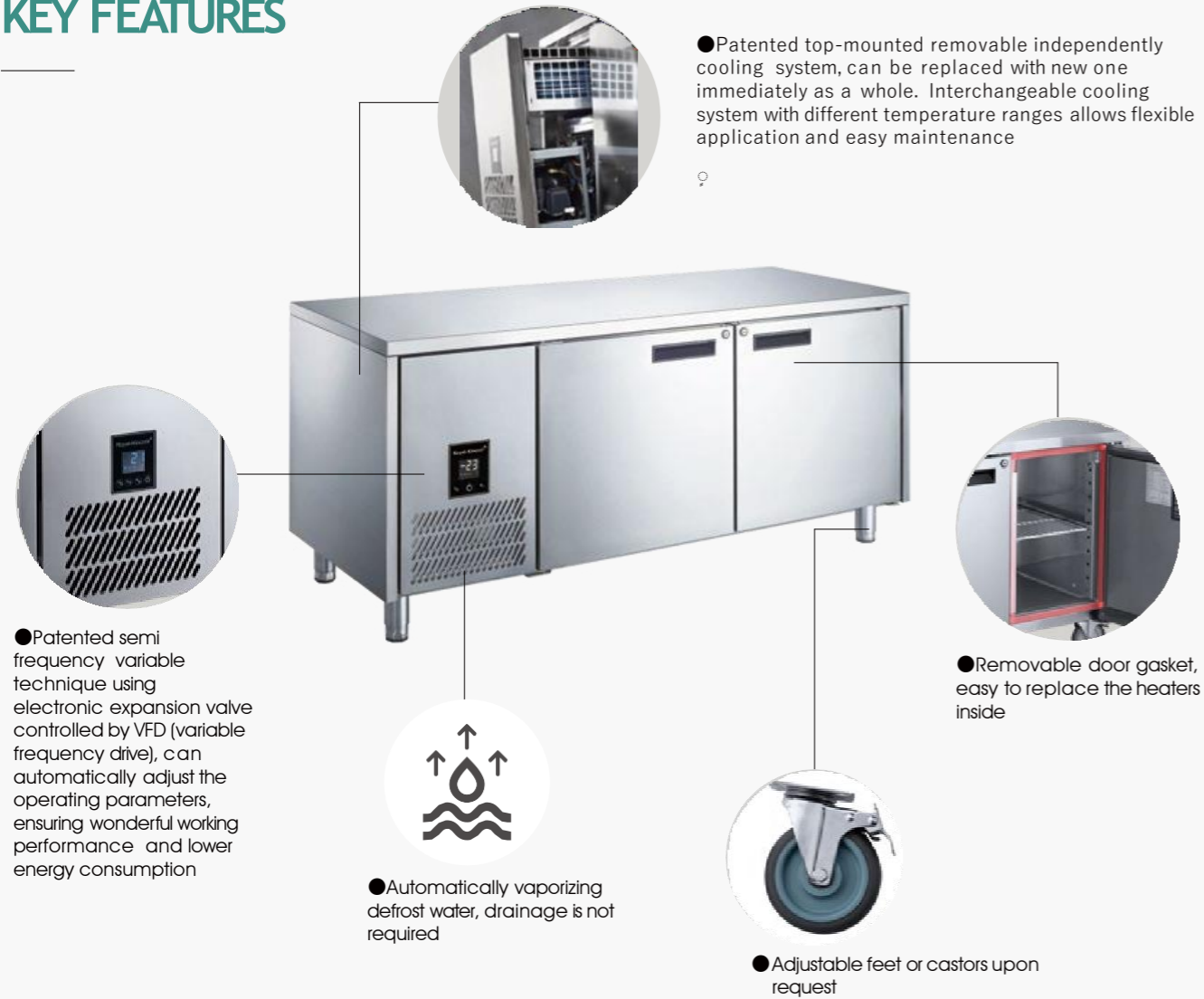

- Accommodating 2/1 GN size
- Foodsafe 304 grade stainless steel exterior and interior
- Galvanized sheet exterior back and base
- Fitted with cylindrical lock for doors

- 1.0 mm thick durable 304 grade stainless steel table top
- Accommodating 400\*600mm bakery pan or GN pan

## OPTIONS

- 304 grade stainless steel exterior and interior back / base
- Heated film glass door
- Pass through door
- Salad plate upon request
- Wooden board under table top
- Table top extension
- 1.2mm thick 304 grade stainless steel table top
- 2,3 or 1/3+2/3 drawers bank
- Cylindrical lock for drawers
- Internal light for door type
- Lock plate
- Right-hand-side condenser unit
- Remoted type condensing unit
- Back/ side splash
- Front/side skirting
- Castors or adjustable feet
- 50 mm height skirting with louvre for sitting on plinth
- Additional shelving/trayslides for door type

## PRODUCT LIST



## COUNTER CHILLER & FREEZER

### TECHNICAL DATA



Model	M-PW6T1H	M-PW6T1N	M-PW6T1D	L-PW6T1H	L-PW6T1N	L-PW6T1D
Temp Range	-2°C ~ 4°C			-18°C ~ -22°C		
Capacity(L)	123			123		
Rating Power	440			750		
Climate Class	4/5/7					
<b>External Dimension (mm)</b>						
Width	955					
Depth	660					
Height	850					
<b>Internal Dimension (mm)</b>						
Width	390					
Depth	563					
Height	558					
<b>Thickness of 304 Grade Stainless Steel (mm)</b>						
Exterior	0.7					
Interior	0.5					
Door or Drawer	0.7					
<b>Open Depth (mm)</b>						
Door Type	1083					
Drawer Type	1266					
<b>Maximum Loading Height of Drawer (mm Per Drawer)</b>						
2 Drawers	150					
3 Drawers	100					
<b>Refrigerant</b>						
Type	R134a			R404a		
<b>Standard Fitting for Door Type</b>						
PE Coated Shelves	1	0	1	1	0	1
Trayslides (Pair)	1	0	1	1	0	1
Packing	Simple package/Carton					
Packing Size	975*680*885mm					
<b>Shipping</b>						
Qty/20GP	34					
Qty/40HQ	70					

Optional Refrigerant: R290



### TECHNICAL DATA



## COUNTER CHILLER & FREEZER

Model	M-PW6T2HH	M-PW6T2NN	M-PW6T2DD	L-PW6T2HH	L-PW6T2NN	L-PW6T2DD
Temp Range	-2°C ~ 4°C			-18°C ~ -22°C		
Capacity(L)	267			267		
Rating Power (W)	460			770		
Climate Class	4/5/7					
<b>External Dimension (mm)</b>						
Width	1420					
Depth	660					
Height	850					
<b>Internal Dimension (mm)</b>						
Width	855					
Depth	563					
Height	558					
<b>Thickness of 304 Grade Stainless Steel (mm)</b>						
Exterior	0.7					
Interior	0.5					
Door or Drawer	0.7					
<b>Open Depth (mm)</b>						
Door Type	1083					
Drawer Type	1266					
<b>Maximum Loading Height of Drawer (mm Per Drawer)</b>						
2 Drawers	150					
3 Drawers	100					
<b>Refrigerant</b>						
Type	R134a			R404a		
<b>Standard Fitting for Door Type</b>						
PE Coated Shelves	2	0	2	2	0	2
Trayslides (Pair)	2	0	2	2	0	2
Packing	Simple package/Carton					
Packing Size	1440*680*885mm					
<b>Shipping</b>						
Qty/20GP	22					
Qty/40HQ	48					

Optional Refrigerant: R290



## COUNTER CHILLER & FREEZER

### TECHNICAL DATA



Model	M-PW6T3HHH	M-PW6T3NNN	M-PW6T3DDD	L-PW6T3HHH	L-PW6T3NNN	L-PW6T3DDD
Temp Range	-2°C ~ 4°C			-18? ~ -22?		
Capacity(L)	420			420		
Rating Power (W)	480			880		
Climate Class	4/5/7					
<b>External Dimension (mm)</b>						
Width	1885					
Depth	660					
Height	850					
<b>Internal Dimension (mm)</b>						
Width	1320					
Depth	563					
Height	558					
<b>Thickness of 304 Grade Stainless Steel (mm)</b>						
Exterior	0.7					
Interior	0.5					
Door or Drawer	0.7					
<b>Open Depth (mm)</b>						
Door Type	1083					
Drawer Type	1266					
<b>Maximum Loading Height of Drawer (mm Per Drawer)</b>						
2 Drawers	150					
3 Drawers	100					
<b>Refrigerant</b>						
Type	R134a			R404a		
<b>Standard Fitting for Door Type</b>						
PE Coated Shelves	3	0	3	3	0	3
Trayslides (Pair)	3	0	3	3	0	3
Packing	Simple package/Carton					
Packing Size	1905*680*885mm					
<b>Shipping</b>						
Qty/20GP	18					
Qty/40HQ	36					

Optional Refrigerant: R290



### TECHNICAL DATA



Model	M-PW6T4HHH	M-PW6T4NNN	M-PW6T4DDD	L-PW6T4HHH	L-PW6T4NNN	L-PW6T4DDD
Temp Range	-2°C ~ 4°C			-18? ~ -22?		
Capacity(L)	590			590		
Rating Power (W)	490			920		
Climate Class	4/5/7					
<b>External Dimension (mm)</b>						
Width	2350					
Depth	660					
Height	850					
<b>Internal Dimension (mm)</b>						
Width	1785					
Depth	563					
Height	558					
<b>Thickness of 304 Grade Stainless Steel (mm)</b>						
Exterior	0.7					
Interior	0.5					
Door or Drawer	0.7					
<b>Open Depth (mm)</b>						
Door Type	1083					
Drawer Type	1266					
<b>Maximum Loading Height of Drawer (mm Per Drawer)</b>						
2 Drawers	<b>150</b>					
3 Drawers	<b>100</b>					
<b>Refrigerant</b>						
Type	R134a			R404a		
<b>Standard Fitting for Door Type</b>						
PE Coated Shelves	4	0	4	4	0	4
Trayslides (Pair)	4	0	4	4	0	4
Packing	Simple package/Carton					
Packing Size	2370*680*885mm					
<b>Shipping</b>						
Qty/20GP	12					
Qty/40HQ	24					

Optional Refrigerant: R290



## COUNTER CHILLER & FREEZER

### TECHNICAL DATA



Model	M-PW7T1H	M-PW7T1N	M-PW7T1D	L-PW7T1H	L-PW7T1N	L-PW7T1D
Temp Range	-2°C ~ 4°C			-18°C ~ -22°C		
Capacity(L)	195			195		
Rating Power (W)	415			449		
Climate Class	4/5/7					
<b>External Dimension (mm)</b>						
Width	1152					
Depth	760					
Height	850					
<b>Internal Dimension (mm)</b>						
Width	587					
Depth	658					
Height	558					
<b>Thickness of 304 Grade Stainless Steel (mm)</b>						
Exterior	0.7					
Interior	0.5					
Door or Drawer	0.7					
<b>Open Depth (mm)</b>						
Door Type	1380					
Drawer Type	1466					
<b>Maximum Loading Height of Drawer (mm Per Drawer)</b>						
2 Drawers	150					
3 Drawers	100					
<b>Refrigerant</b>						
Type	R134a			R404a		
<b>Standard Fitting for Door Type</b>						
PE Coated Shelves	1	0	1	1	0	1
Trayslides (Pair)	1	0	1	1	0	1
Packing	Simple package/Carton					
Packing Size	1175*780*885mm					
<b>Shipping</b>						
Qty/20GP	22					
Qty/40HQ	46					

Optional Refrigerant: R290



### TECHNICAL DATA



## COUNTER CHILLER & FREEZER

Model	M-PW7T2HH	M-PW7T2NN	M-PW7T2DD	L-PW7T2HH	L-PW7T2NN	L-PW7T2DD
Temp Range	-2°C ~ 4°C			-18°C ~ -22°C		
Capacity(L)	416			416		
Rating Power	430			660		
Climate Class	4/5/7					
<b>External Dimension (mm)</b>						
Width	1815					
Depth	760					
Height	850					
<b>Internal Dimension (mm)</b>						
Width	1249					
Depth	658					
Height	558					
<b>Thickness of 304 Grade Stainless Steel (mm)</b>						
Exterior	0.7					
Interior	0.5					
Door or Drawer	0.7					
<b>Open Depth (mm)</b>						
Door Type	1380					
Drawer Type	1466					
<b>Maximum Loading Height of Drawer (mm Per Drawer)</b>						
2 Drawers	150					
3 Drawers	100					
<b>Refrigerant</b>						
Type	R134a			R404a		
<b>Standard Fitting for Door Type</b>						
PE Coated Shelves	2	0	2	2	0	2
Trayslides (Pair)	2	0	2	2	0	2
Packing	Simple package/Carton					
Packing Size	1835*780*885mm					
<b>Shipping</b>						
Qty/20GP	14					
Qty/40HQ	28					

Optional Refrigerant: R290



## COUNTER CHILLER & FREEZER

### TECHNICAL DATA



Model	M-PW7T3HHH	M-PW7T3NNN	M-PW7T3DDD
Temp Range	-18°C ~ -22 °C		
Capacity(L)	637		
Rating Power (W)	510		
Climate Class	4/5/7		
<b>External Dimension (mm)</b>			
Width	2476		
Depth	760		
Height	850		
<b>Internal Dimension (mm)</b>			
Width	1911		
Depth	658		
Height	558		
<b>Thickness of 304 Grade Stainless Steel (mm)</b>			
Exterior	0.7		
Interior	0.5		
Door or Drawer	0.7		
<b>Open Depth (mm)</b>			
Door Type	1380		
Drawer Type	1466		
<b>Maximum Loading Height of Drawer (mm Per Drawer)</b>			
2 Drawers	150		
3 Drawers	100		
<b>Refrigerant</b>			
Type	R134a		
<b>Standard Fitting for Door Type</b>			
PE Coated Shelves	3	0	3
Trayslides (Pair)	3	0	3
Packing	Simple package/Carton		
Packing Size	2495*780*885mm		
<b>Shipping</b>			
Qty/20GP	8		
Qty/40HQ	16		

Optional Refrigerant: R290



### TECHNICAL DATA



Model	L-PW7T3HHH	L-PW7T3NNN	L-PW7T3DDD
Temp Range	-18°C ~ -22°C		
Capacity(L)	637		
Rating Power (W)	660		
Climate Class	4/5/7		
<b>External Dimension (mm)</b>			
Width	2476		
Depth	760		
Height	850		
<b>Internal Dimension (mm)</b>			
Width	1911		
Depth	658		
Height	558		
<b>Thickness of 304 Grade Stainless Steel (mm)</b>			
Exterior	0.7		
Interior	0.5		
Door or Drawer	0.7		
<b>Open Depth (mm)</b>			
Door Type	1380		
Drawer Type	1466		
<b>Maximum Loading Height of Drawer (mm Per Drawer)</b>			
2 Drawers	150		
3 Drawers	100		
<b>Refrigerant</b>			
Type	R404a		
<b>Standard Fitting for Door Type</b>			
PE Coated Shelves	3	0	3
Trayslides (Pair)	3	0	3
Packing	Simple package/Carton		
Packing Size	2495*780*885mm		
<b>Shipping</b>			
Qty/20GP	8		
Qty/40HQ	16		

Optional Refrigerant: R290



# COUNTER CHILLER & FREEZER (PASS THROUGH TYPE)

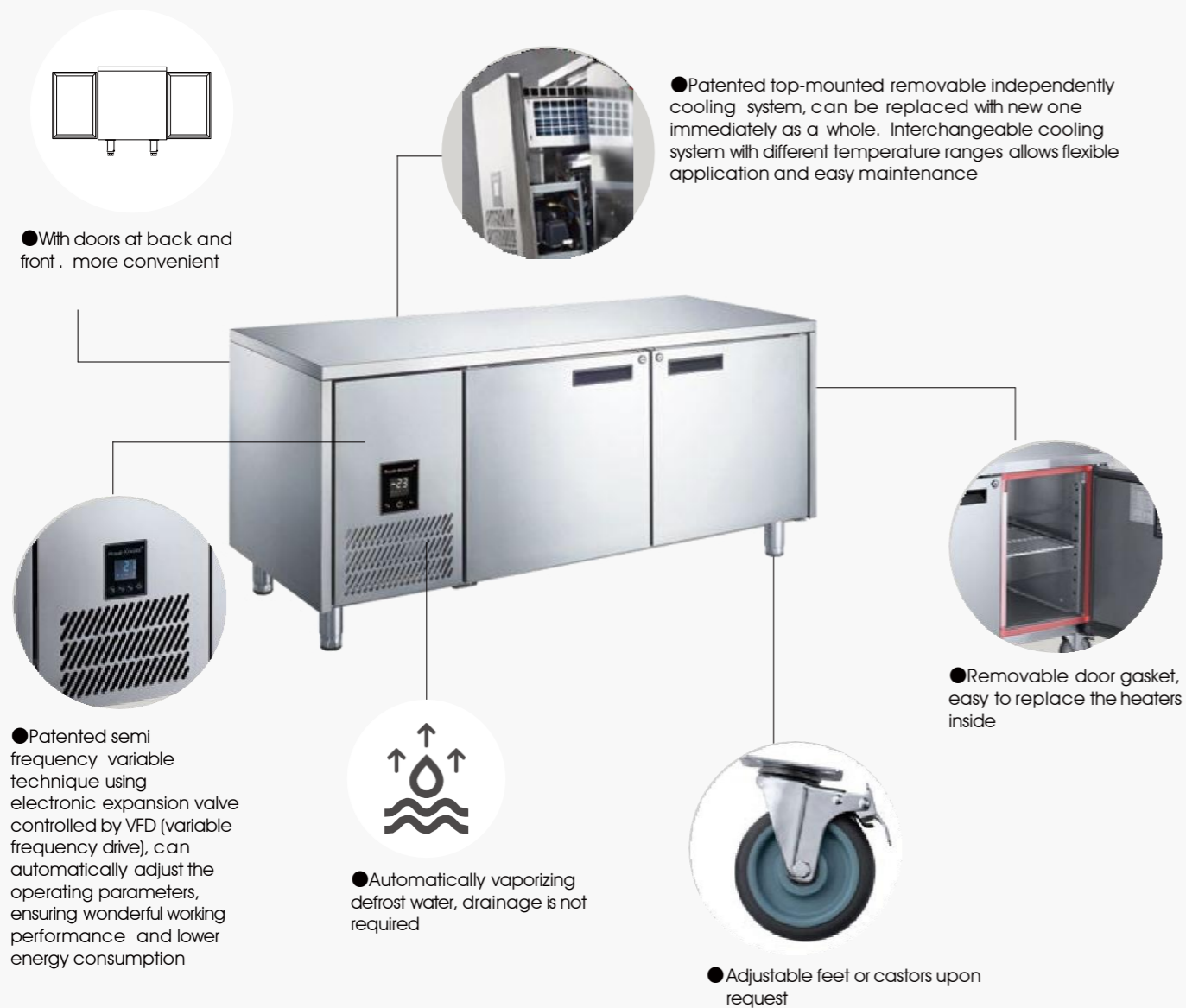

## SPECIFICATIONS

- Accommodating 2/1 GN size
- Foodsafe 304 grade stainless steel exterior and interior
- Galvanized sheet exterior base
- Fitted with cylindrical lock for doors
- 1.0 mm thick durable 304 grade stainless steel table top
- Accomodating 400\*600mm bakery pan or GN pan

- 304 grade stainless steel exterior and interior back / base
- Heated film glass door
- Pass through door
- Salad plate upon request
- Wooden board under table top
- Table top extension
- 1.2mm thick 304 grade stainless steel table top
- 2,3 or 1/3+2/3 drawers bank
- Cylindrical lock for drawers
- Internal light for door type
- Lock plate

- Right-hand-side condenser unit
- Remoted type condensing unit
- Back/ side splash
- Front/side skirting
- Castors or adjustable feet
- 50 mm height skirting with louvre for sitting on plinth
- Additional shelving/trayslides for door type

## PRODUCT LIST



## COUNTER CHILLER & FREEZER (PASS THROUGH TYPE)

### TECHNICAL DATA



Model	M-PW6T1H-P	L-PW6T1H-P	M-PW6T2HH-P	L-PW6T2HH-P
Temp Range	-2°C ~ 4°C	-18°C ~ -22°C	-2°C ~ 4°C	-18°C ~ -22°C
Capacity(L)	123		267	
Rating Power (W)	440	750	460	770
Climate Class	4/5/7			
<b>External Dimension (mm)</b>				
Width	955		1420	
Depth	660			
Height	850			
<b>Internal Dimension (mm)</b>				
Width	390		855	
Depth	546			
Height	558			
<b>Thickness of 304 Grade Stainless Steel (mm)</b>				
Exterior	0.7			
Interior	0.5			
Door or Drawer	0.7			
<b>Open Depth (mm)</b>				
Door type	1510			
Compressor (HP)	1/4	1/4	1/4	1/
<b>Refrigerant</b>				
Type	R134a	R404a	R134a	R404a
<b>Standard Fitting for Door Type</b>				
PE Coated Shelves	1		2	
Trayslides (Pair)	1		2	
Packing	Simple package/Carton			
Packing Size	975*680*885mm		1440*680*885mm	
<b>Shipping</b>				
Qty/20GP	34		22	
Qty/40HQ	70		48	

Optional Refrigerant: R290

### TECHNICAL DATA



## COUNTER CHILLER & FREEZER (PASS THROUGH TYPE)

Model	M-PW6T3HHH-P	L-PW6T3HHH-P	M-PW6T4HHHH-P	L-PW6T4HHHH-P
Temp Range	-2°C ~ 4°C	-18°C ~ -22°C	-2°C ~ 4°C	-18°C ~ -22°C
Capacity(L)	420		590	
Rating Power	480	880	490	920
Climate Class	4/5/7			
<b>External Dimension (mm)</b>				
Width	1885		2350	
Depth	660			
Height	850			
<b>Internal Dimension (mm)</b>				
Width	1320		1785	
Depth	546			
Height	558			
<b>Thickness of 304 Grade Stainless Steel (mm)</b>				
Exterior	0.7			
Interior	0.5			
Door or Drawer	0.7			
<b>Open Depth (mm)</b>				
Door type	1510			
Compressor (HP)	1/1	1/1	/	
<b>Refrigerant</b>				
Type	R134a	R404a	R134a	R404a
<b>Standard Fitting for Door Type</b>				
PE Coated Shelves	3		4	
Trayslides (Pair)	3		4	
Packing	Simple package/Carton			
Packing Size	1905*680*885mm		2370*680*885mm	
<b>Shipping</b>				
Qty/20GP	18		12	
Qty/40HQ	36		24	

Optional Refrigerant: R290

## COUNTER CHILLER & FREEZER (PASS THROUGH TYPE)

### TECHNICAL DATA



Model	M-PW7T1H-P	L-PW7T1H-P	M-PW7T2HH-P
Temp Range	-2°C ~ 4°C	-18°C ~ -22°C	-2°C ~ 4°C
Capacity(L)	195	195	416
Rating Power (W)	415	449	430
Climate Class	4/5/7		
<b>External Dimension (mm)</b>			
Width	1152		1815
Depth		760	
Height		850	
<b>Internal Dimension (mm)</b>			
Width	587		1249
Depth		646	
Height		558	
<b>Thickness of 304 Grade Stainless Steel (mm) #304</b>			
Exterior		0.7	
Interior		0.5	
Door or Drawer		0.7	
<b>Open Depth (mm)</b>			
Door Type		1610	
Compressor (HP)	1/4	3/8	1/4
<b>Refrigerant</b>			
Type	R134a	R404a	R134a
<b>Standard Fitting for Door Type</b>			
PE Coated Shelves	1		2
Trayslides (Pair)	1		2
Packing	Simple package/Carton		
Packing Size	1175*780*885mm		1835*780*885mm
<b>Shipping</b>			
Qty/20GP	22		14
Qty/40HQ	46		28

Optional Refrigerant: R290

### TECHNICAL DATA



## COUNTER CHILLER & FREEZER (PASS THROUGH TYPE)

Model	L-PW7T2HH-P	M-PW7T3HHH-P	L-PW7T3HHH-P
Temp Range	-18°C ~ -22°C	-2°C ~ 4°C	-18°C ~ -22°C
Capacity(L)	416		637
Rating Power	660	510	660
Climate Class	4/5/7		
<b>External Dimension (mm)</b>			
Width	1815		2476
Depth		760	
Height		850	
<b>Internal Dimension (mm)</b>			
Width	1249		1911
Depth		646	
Height		558	
<b>Thickness of 304 Grade Stainless Steel (mm) #304</b>			
Exterior		0.7	
Interior		0.5	
Door or Drawer		0.7	
<b>Open Depth (mm)</b>			
Door Type		1610	
Compressor (HP)	1/2	3/8	3/4
<b>Refrigerant</b>			
Type	R404a	R134a	R404a
<b>Standard Fitting for Door Type</b>			
PE Coated Shelves	2		3
Trayslides (Pair)	2		3
Packing	Simple package/Carton		
Packing Size	1835*780*885mm		2495*780*885mm
<b>Shipping</b>			
Qty/20GP	14		8
Qty/40HQ	28		16

Optional Refrigerant: R290



# COUNTER CHILLER&FREEZER WITH REMOTE CONDENSATION UNIT

## KEY FEATURES

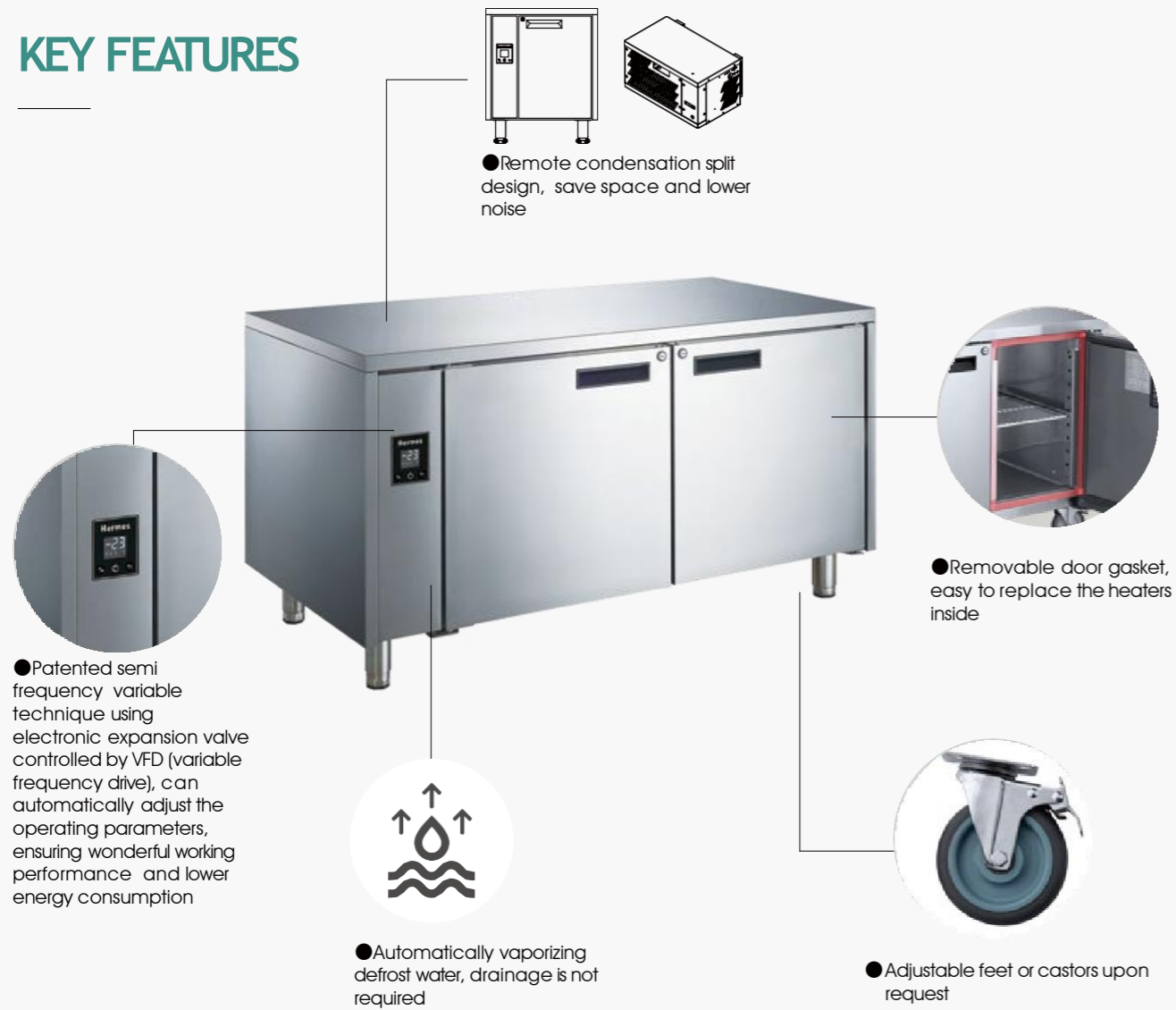

- Accommodating 2/1 GN size  
2/1 GN
- Foodsafe 304 grade stainless steel exterior and interior  
304 SS
- Galvanized sheet exterior back and base  
Galvanized
- Fitted with cylindrical lock for doors  
Cylindrical lock
- 1.0 mm thick durable 304 grade stainless steel table top  
1.0mm 304 SS
- Accomodating 400\*600mm bakery pan or GN pan  
400\*600mm GN

## OPTIONS

- 304 grade stainless steel exterior and interior back / base
- Heated film glass door
- Pass through door
- Salad plate upon request
- Wooden board under table top
- Table top extension
- 1.2mm thick 304 grade stainless steel table top
- 2,3 or 1/3+2/3 drawers bank
- Cylindrical lock for drawers
- Internal light for door type
- Lock plate
- Right-hand-side condenser unit
- Remoted type condensing unit
- Back/ side splash
- Front/side skirting
- Castors or adjustable feet
- 50 mm height skirting with louvre for sitting on plinth
- Additional shelving/trayslides for door type

T1H-S



T2HH-S



T3HHH-S



T4HHHH-S



## COUNTER CHILLER & FREEZER WITH REMOTE CONDENSATION UNIT

### TECHNICAL DATA



Model	M-PW6T1H-S	L-PW6T1H-S	M-PW7T1H-S	L-PW7T1H-S
Temp Range	-2°C ~ 4°C	-18°C ~ -22°C	-2°C ~ 4°C	-18°C ~ -22°C
Capacity(L)	123		195	
Rating Power (W)	550	660	430	660
Climate Class	4/5/7			
<b>External Dimension (mm)</b>				
Width	705		902	
Depth	660		760	
Height	850			
<b>Internal Dimension (mm)</b>				
Width	390		587	
Depth	563		658	
Height	558			
<b>Thickness of 304 Grade Stainless Steel (mm) #304</b>				
Exterior	0.7			
Interior	0.5			
Door or Drawer	0.7			
<b>Open Depth (mm)</b>				
Door Type	1083		1380	
Drawer Type	1266		1466	
<b>Maximum Loading Height of Drawer (mm Per Drawer)</b>				
2 Drawers	150			
3 Drawers	100			
Compressor (HP)	3/8	1/2	1/4	1/2
<b>Refrigerant</b>				
Type	R134a	R404a	R134a	R404a
<b>Standard Fitting for Door Type</b>				
PE Coated Shelves	1		1	
Trayslides (Pair)	1		1	
Packing	Simple package/Carton			
<b>Packing Size</b>				
Cabinet	765*720*910		962*820*910	
Condensation Unit	580*395*680			
<b>Shipping</b>				
Qty/20GP	35	35	24	24
Qty/40HQ	73	73	48	48

Optional Refrigerant: R290

### TECHNICAL DATA



## COUNTER CHILLER & FREEZER WITH REMOTE CONDENSATION UNIT

Model	M-PW6T2HH-S	L-PW6T2HH-S	M-PW7T2HH-S	L-PW7T2HH-S
Temp Range	-2°C ~ 4°C	-18°C ~ -22°C	-2°C ~ 4°C	-18°C ~ -22°C
Capacity(L)	267		416	
Rating Power (W)	550	675	450	660
Climate Class	4/5/7			
<b>External Dimension (mm)</b>				
Width	1170		1565	
Depth	660		760	
Height	850			
<b>Internal Dimension (mm)</b>				
Width	855		1249	
Depth	563		658	
Height	558			
<b>Thickness of 304 Grade Stainless Steel (mm) #304</b>				
Exterior	0.7			
Interior	0.5			
Door or Drawer	0.7			
<b>Open Depth (mm)</b>				
Door Type	1083		1380	
Drawer Type	1266		1466	
<b>Maximum Loading Height of Drawer (mm Per Drawer)</b>				
2 Drawers	150			
3 Drawers	100			
Compressor (HP)	3/8	1/2	3/8	3/4
<b>Refrigerant</b>				
Type	R134a	R404a	R134a	R404a
<b>Standard Fitting for Door Type</b>				
PE Coated Shelves	2		2	
Trayslides (Pair)	2		2	
Packing	Simple package/Carton			
<b>Packing Size</b>				
Cabinet	1230*720*910		1625*820*910	
Condensation Unit	580*395*680			
<b>Shipping</b>				
Qty/20GP	23	23	14	14
Qty/40HQ	50	50	28	28

Optional Refrigerant: R290

## COUNTER CHILLER & FREEZER WITH REMOTE CONDENSATION UNIT

### TECHNICAL DATA



Model	M-PW6T3HHH-S	L-PW6T3HHH-S
Temp Range	-2°C ~ 4°C	-18°C ~ 22°C
Capacity(L)	420	
Rating Power (W)	430	660
Climate Class	4/5/7	
<b>External Dimension (mm)</b>		
Width	1635	
Depth	660	
Height	850	
<b>Internal Dimension (mm)</b>		
Width	1320	
Depth	563	
Height	558	
<b>Thickness of 304 Grade Stainless Steel (mm) #304</b>		
Exterior	0.7	
Interior	0.5	
Door or Drawer	0.7	
<b>Open Depth (mm) fl</b>		
Door Type	1083	
Drawer Type	1266	
<b>Maximum Loading Height of Drawer (mm Per Drawer)</b>		
2 Drawers	150	
3 Drawers	100	
Compressor (HP)	1/2	1/2
<b>Refrigerant</b>		
Type	R134a	R404a
<b>Standard Fitting for Door Type</b>		
PE Coated Shelves	3	3
Trayslides (Pair)	3	3
Packing	Simple package/Carton	
<b>Packing Size</b>		
Cabinet	1695*720*910	
Condensation Unit	580*395*680	
<b>Shipping</b>		
Qty/20GP	18	18
Qty/40HQ	38	38

### TECHNICAL DATA



## COUNTER CHILLER & FREEZER WITH REMOTE CONDENSATION UNIT

Model	M-PW7T3HHH-S	L-PW7T3HHH-S
Temp Range	-2°C ~ 4°C	-18°C ~ 22°C
Capacity	637	
Rating Power	450	730
Climate Class	4/5/7	
<b>External Dimension (mm)</b>		
Width	2226	
Depth	760	
Height	850	
<b>Internal Dimension (mm)</b>		
Width	1911	
Depth	658	
Height	558	
<b>Thickness of 304 Grade Stainless Steel (mm) #304</b>		
Exterior	0.7	
Interior	0.5	
Door or Drawer	0.7	
<b>Open Depth (mm)</b>		
Door Type	1380	
Drawer Type	1466	
<b>Maximum Loading Height of Drawer (mm Per Drawer)</b>		
2 Drawers	150	
3 Drawers	100	
Compressor (HP)	/	/
<b>Refrigerant</b>		
Type	R134a	R404a
<b>Standard Fitting for Door Type</b>		
PE Coated Shelves	3	3
Trayslides (Pair)	3	3
Packing	Simple package/Carton	
<b>Packing Size</b>		
Cabinet	2286*820*910	
Condensation Unit	580*395*680	
<b>Shipping</b>		
Qty/20GP	13	13
Qty/40HQ	26	26

Optional Refrigerant: R290

## KEY FEATURES

- Patented top-mounted removable independently cooling system, can be replaced with new one immediately as a whole. Interchangeable cooling system with different temperature ranges allows flexible application and easy maintenance
- The working table top is sufficient for a 12" pizza dough
- Unique airflow design with protective air curtain ensures the food in the GN pan fresh
- Patented semi frequency variable technique using electronic expansion valve controlled by VFD (variable frequency drive), can automatically adjust the operating parameters, ensuring wonderful working performance and lower energy consumption
- Automatically vaporizing defrost water, drainage is not required
- Removable door gasket, easy to replace the heaters inside
- Adjustable feet or castors upon request

- Accommodating 2/1 GN size  
٢/١ ج.ن
- Foodsafe 304 grade stainless steel exterior and interior  
٣٠٤ ج.ن
- Galvanized sheet exterior back and base  
٣٠٤ ج.ن
- Fitted with cylindrical lock for doors  
٣٠٤ ج.ن

- 1.0 mm thick durable 304 grade stainless steel table top  
١.٠ ج.ن
- Accommodating 400\*600mm bakery pan or GN pan  
٤٠٠\*٦٠٠ ج.ن

## OPTIONS

- 304 grade stainless steel exterior and interior back / base
- Heated film glass door
- Pass through door
- Salad plate upon request
- Wooden board under table top
- Table top extension
- 1.2mm thick 304 grade stainless steel table top
- 2,3 or 1/3+2/3 drawers bank
- Cylindrical lock for drawers
- Internal light for door type
- Lock plate
- Right-hand-side condenser unit
- Remoted type condensing unit
- Back/ side splash
- Front/side skirting
- Castors or adjustable feet
- 50 mm height skirting with louvre for sitting on plinth
- Additional shelving/trayslides for door type



## PIZZA CABINET

### TECHNICAL DATA



Model	PW10H	PW20HH	PW30HHH
Temp Range	-2°C ~ 4°C	-2°C ~ 4°C	-2°C ~ 4°C
Capacity(L)	216	416	656
Rating Power (W)	420	450	542
Climate Class	4/5/7		
<b>External Dimension (mm)</b>			
Width	1152	1815	2476
Depth	760		
Height	1050		
<b>Internal Dimension (mm)</b>			
Width	587	1249	1911
Depth	658		
Height	558		
<b>Thickness of 304 Grade Stainless Steel (mm) #304</b>			
Exterior	0.7		
Interior	0.5		
Door or drawer	0.7		
<b>Open Depth (mm)</b>			
Door Type	1380		
Drawer Type	1466		
<b>GN pan</b>			
Quantity	4 or 5	8 or 9	12
Size(mm)	325*176*150		
<b>Maximum Loading Height of Drawer (mm Per Drawer) ㉵gōr☒☒rg</b>			
2 Drawers	150		
3 Drawers	100		
Compressor (HP)	1/4	3/8	3/8
<b>Refrigerant</b>			
Type	R134a		
<b>Standard Fitting for Door Type</b>			
PE Coated Shelve	1	2	3
Trayslides (Pair)	1	2	3
Packing	Simple package/Carton		
Packing Size	1212*820*1250	1875*820*1250	2536*820*1250
<b>Shipping</b>			
Qty/20GP	22	14	8
Qty/40HQ	46	28	16

Optional Refrigerant: R290

### TECHNICAL DATA



## PIZZA CABINET

Model	PW10N	PW20NN	PW30NNN
Temp Range	-2°C ~ 4°C	-2°C ~ 4°C	-2°C ~ 4°C
Capacity(L)	216	416	656
Rating Power	420	450	542
Climate Class	4/5/7		
<b>External Dimension (mm)</b>			
Width	1152	1815	2476
Depth	760		
Height	1050		
<b>Internal Dimension (mm)</b>			
Width	587	1249	1911
Depth	658		
Height	558		
<b>Thickness of 304 Grade Stainless Steel (mm) #304</b>			
Exterior	0.7		
Interior	0.5		
Door or drawer	0.7		
<b>Open Depth (mm)</b>			
Door Type	1380		
Drawer Type	1466		
<b>GN pan</b>			
Quantity	4 or 5	8 or 9	12
Size(mm)	325*176*150		
<b>Maximum Loading Height of Drawer (mm Per Drawer)</b>			
2 Drawers	150		
3 Drawers	100		
Compressor (HP)	1/4	3/8	3/8
<b>Refrigerant</b>			
Type	<b>R134a</b>		
<b>Standard Fitting for Door Type</b>			
PE Coated Shelves	0	0	0
Trayslides (Pair)	0	0	0
Packing	Simple package/Carton		
Packing Size	1212*820*1250	1875*820*1250	2536*820*1250
<b>Shipping</b>			
Qty/20GP	22	14	8
Qty/40HQ	46	28	16

Optional Refrigerant: R290

## KEY FEATURES

- Patented top-mounted removable independently cooling system, can be replaced with new one immediately as a whole. Interchangeable cooling system with different temperature ranges allows flexible application and easy maintenance
- Patented semi frequency variable technique using electronic expansion valve controlled by VFD (variable frequency drive), can automatically adjust the operating parameters, ensuring wonderful working performance and lower energy consumption
- Adjustable feet or castors upon request
- Removable door gasket, easy to replace the heaters inside
- Automatically vaporizing defrost water, drainage is not required

● Foodsafe 304 grade stainless steel exterior and interior

● Galvanized sheet exterior back and base

● Fitted with cylindrical lock for doors

● 1.0 mm thick durable 304 grade stainless steel table top

### OPTIONS

- 304 grade stainless steel exterior and interior back / base
- Heated film glass door
- Pass through door
- Salad plate upon request
- Wooden board under table top
- Table top extension
- 1.2mm thick 304 grade stainless steel table top
- 2, 3 or 1/3+2/3 drawers bank
- Cylindrical lock for drawers
- Internal light for door type
- Lock plate
- Right-hand-side condenser unit
- Remoted type condensing unit
- Back/ side splash
- Front/side skirting
- Castors or adjustable feet
- 50mm height skirting with louvre for sitting on plinth
- Additional shelving/trayslides for door type
- Accommodating 2/1 GN size
- Accommodating 400\*600mm bakery pan or GN pan

## TECHNICAL DATA



Model	T-W6T1N	T-W6T2NN	T-W6T3NNN	T-W7T1N	T-W7T2NN
Temp Range	-2°C ~ 4°C				
Capacity(L)	128	212	300	128	212
Rating Power (W)	412	290	350	412	290
Climate Class	4/5/7				
<b>External Dimension (mm)</b>					
Width	1145	1602	2060	1349	2012
Depth	660		760		
Height	550		550		
<b>Internal Dimension (mm)</b>					
Width	370	827	1284	598	1260
Depth	563		663		
Height	362		362		
<b>Thickness of 304 Grade Stainless Steel (mm) #304</b>					
Exterior	0.7				
Interior	0.5				
Door or Drawer	0.7				
<b>Open Depth (mm)</b>					
Door Type	1083			1380	
Drawer Type	1266			1466	
<b>Maximum Loading Height of Drawer (mm Per Drawer)</b>					
2 Drawers	105				
Compressor (HP)	1/2	1/3	3/8	1/2	1/3
<b>Refrigerant</b>					
Type	R134a				
<b>Standard Fitting for Door Type</b>					
GN pan GN	/	/	/	/	/
Trayslides (Pair)	/	/	/	/	/
Packing	Simple package/Carton				
Packing Size	1205*720*675mm	1662*720*675mm	2120*720*675mm	1409*820*675mm	2072*820*675mm
<b>Shipping</b>					
Qty/20GP	39	30	24	33	21
Qty/40HQ	84	63	48	66	42

Optional Refrigerant: R290



**Banquet  
Cart  
Chiller &  
Warmer**

**LFSUSA.STORE**

# BANQUET CART CHILLER & WARMER

## GENERAL FEATURES

- GN pan designed
- High density 75mm thick insulation foam with zero ODP (Ozone Depletion Potential) and low GWP (Global Warming Potential)
- Over 90 degree door opening allows easy loading and stock checking
- Environmental-friendly CFC-free refrigerant (R134a/R290);
- Designed and engineered to operate at the ambient temp from 0 °C to 43 °C
- Equipped with automatic re-set safety cutout switch to prevent overheating
- Automatically vaporizing defrost water, drainage is not required
- Self-developed controlling system can examine the faulty automatically, and display the relative codes on the digital controller, which makes the maintenance much easier and more effective
- Hot gas defrost ensures the evaporator working to its optimum performance
- Audible and visual Er4, door open (over 3 minutes) alarm for freezer ensures food quality and minimises energy consumption
- The evaporator fan motor stops once the door opens to reduce energy consumption
- Fitted with circulation fans to ensure even temperature and fast warm-up throughout the cabinet



● 304 stainless steel exterior and interior finish, provides high corrosion resistance properties, ensuring food safety standard



● Built-in handles at four sides for easy mobility



● 155mm heavy duty, non-marking swivel and braked castors for easy positioning



● Round corners design, easy for cleaning



● Adjustable anti-tilt trayslides, match GN design



● Patented semi frequency variable technique using electronic expansion valve controlled by VFD (variable frequency drive), can automatically adjust the operating parameters, ensuring wonderful working performance and lower energy consumption



● Self-closing doors design prevents heat ingress and reduces energy consumption

## BANQUET CART CHILLER & WARMER



## TECHNICAL DATA

Model	P16HF	P16SF
<b>Temp Range</b>	70°C ~ 82°C	-2°C ~ 4°C
<b>Capacity(L)</b>	345	428
<b>Rating Power</b>	1400	490
<b>Climate Class</b>	4/5/7	
<b>External Dimension (mm)</b>		
<b>Width</b>	781	781
<b>Depth</b>	872	885
<b>Height</b>	1770	2000
<b>Internal Dimension (mm)</b>		
<b>Width</b>	588	588
<b>Depth</b>	680	680
<b>Height</b>	1315	1220
<b>Thickness of 304 Grade Stainless Steel (mm) #304</b>		
<b>Exterior</b>	0.7	
<b>Interior</b>	0.5	
<b>Door or Drawer</b>	0.7	
<b>Open Depth (mm)</b>		
<b>Door Type</b>	1430	
<b>Compressor (HP)</b>	/	1/4
<b>Refrigerant</b>		
<b>Type</b>	/	R134a
<b>Standard Fitting for Door Type</b>		
<b>GN pan GN</b>	16	16
<b>Packing</b>	Simple package/Carton	
<b>Packing Size</b>	840*960*1845	860*960*2180
<b>Shipping</b>		
<b>Qty/20GP</b>	12	12
<b>Qty/40HQ</b>	26	26

Optional Refrigerant: R290





# Beverage Collection



LFSUSA.STORE

# BEVERAGE COLLECTION

## GENERAL FEATURES

Designed for stylishness, effective storage and display of bottles and cans for easy customer selection

- Fitted with anti-condensation ITO glass door with stainless steel frame
- Engineered with hidden condensing unit to fit with interior design and minimize the requested installation space
- Automatically vaporizing defrost water, drainage is not required.
- Evaporator with coated fins provides high corrosion resistance properties
- Hot gas defrost ensures the evaporator working to its optimum performance
- Environmental-friendly CFC-free refrigerant



## TECHNICAL DATA

## UNDER BAR COOLER

Model	M-PSS8L1	M-PSS8L2	M-PSS8L3	M-PSS9L1	M-PSS9L2	M-PSS9L3
<b>Temp Range</b>	4°C ~ 10°C					
<b>Capacity(L)</b>	80	125	240	93	160	264
<b>Rating Power (W)</b>	210	240	420	225	260	435
<b>Climate Class</b>	3					
<b>External Dimension (mm)</b>						
<b>Width</b>	600	900	1350	600	900	1350
<b>Depth</b>	520					
<b>Height</b>	800	800	800	900	900	900
<b>Packing Size (mm)</b>						
<b>Packing</b>	Plywood Case					
<b>Width</b>	650	950	1400	650	950	1400
<b>Depth</b>	570					
<b>Height</b>	950			1100		
<b>Weight (kgs) ☒</b>						
<b>Net weight</b>	65	80	100	75	84	120
<b>Gross weight</b>	95	110	130	95	104	150
<b>Door Opening Direction</b>						
<b>Door type</b>	1070					
<b>Compressor (HP)</b>	1/5	1/5	1/4	1/5	1/5	1/4
<b>Refrigerant</b>						
<b>Type</b>	R134a					
<b>Shipping</b>						
<b>Qty/20GP</b>	54	42	26	54	42	26
<b>Qty/40HQ</b>	120	88	56	120	88	56

Optional Refrigerant: R290

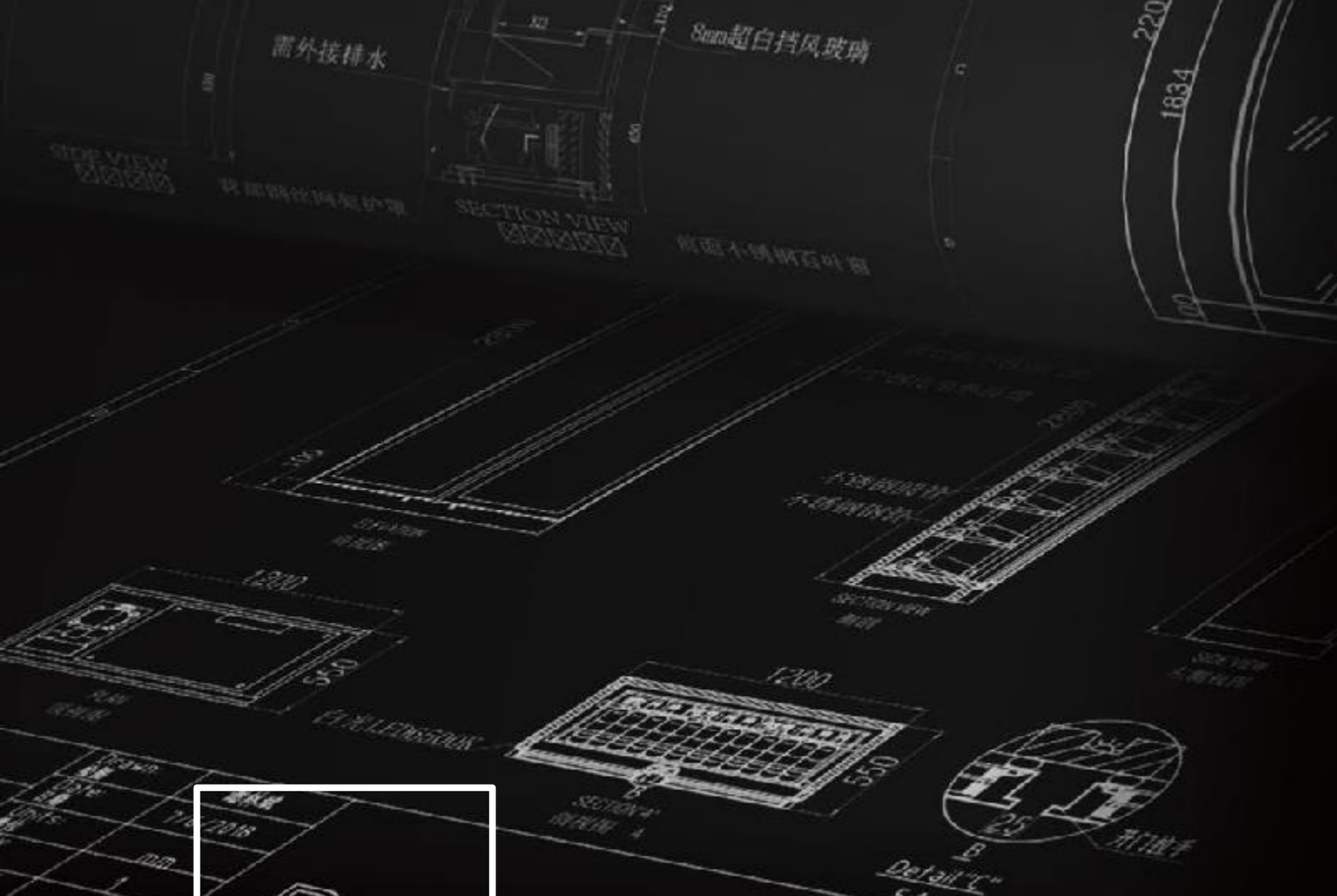

Customized  
Collection

LFSUSA.STORE

Red Wine Cabinet

1/2



Cold Bain-marie

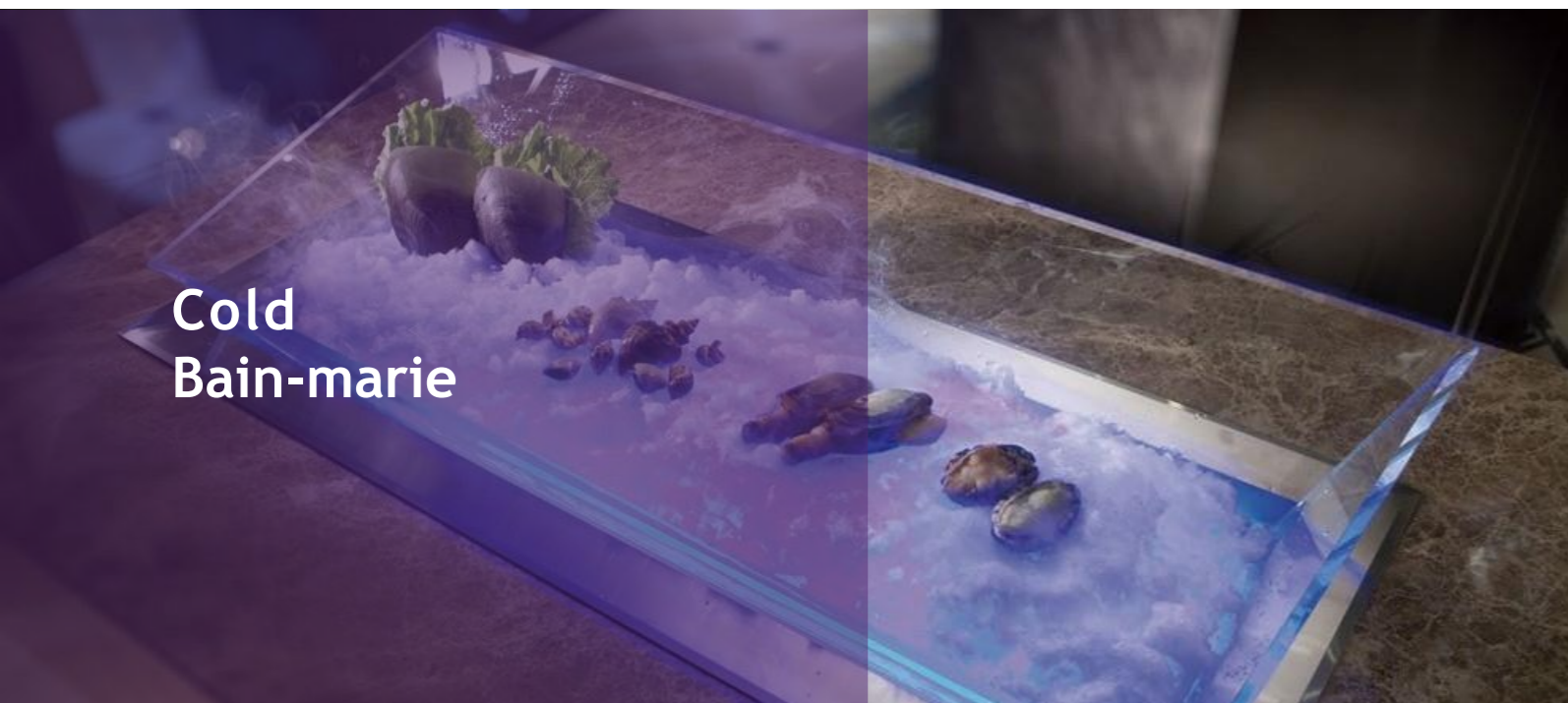

Freezing Plate

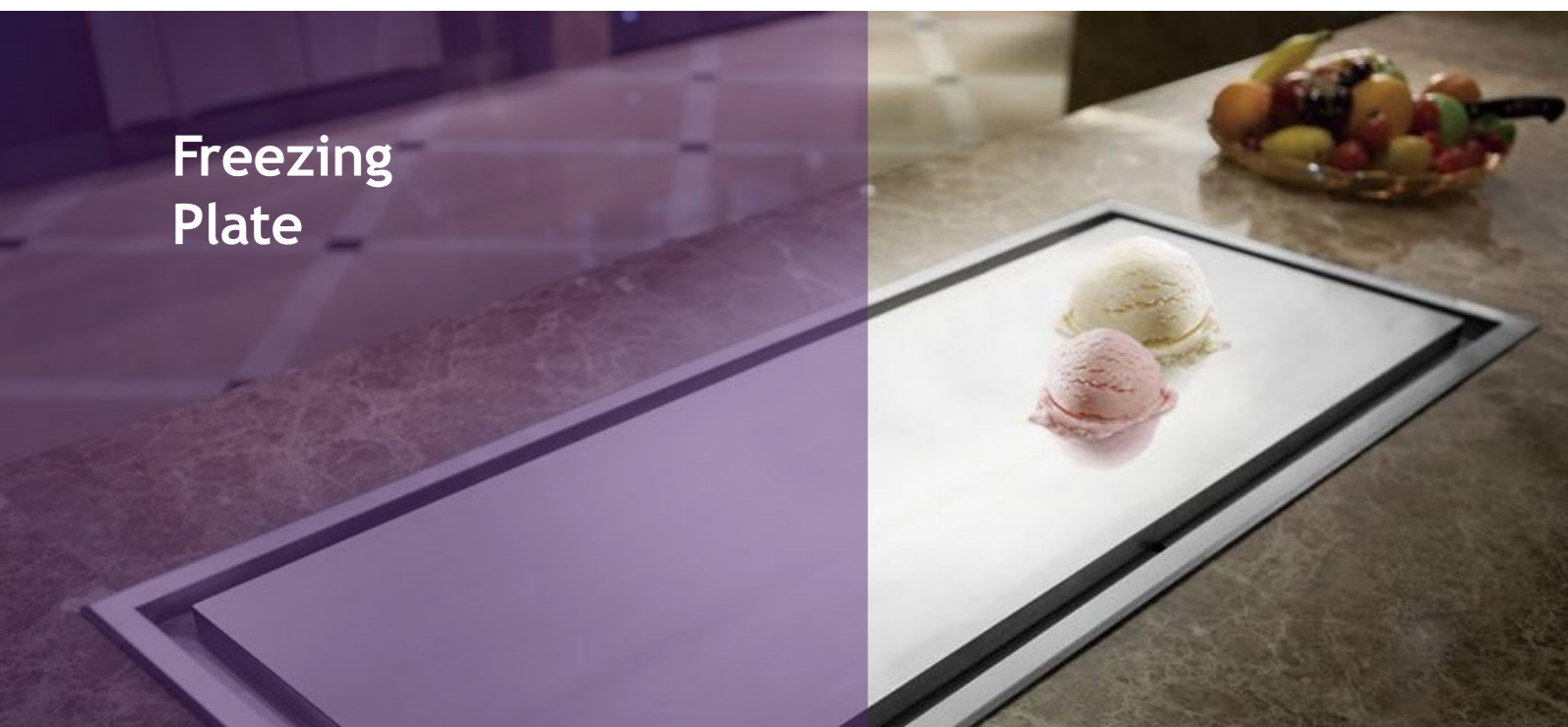

Vegetable Cabinet



LFSUSA.STORE