



# UNDER-COUNTER/WORK TOP REFRIGERATORS WITH DRAWERS

CONTACT US:

**Customer Service:**  
+1 (786) 584-7439

**Sales Team:**  
+1 (786) 860-2528

**Email:**  
sales@lfsusa.store

[www.lfsusa.store](http://www.lfsusa.store)



## COMPETITOR SERIES®



C-U27R-D-HC



C-U48R-D-HC



C-U60R-D-HC

# UNDER-COUNTER/WORK TOP REFRIGERATORS WITH DRAWERS

- Beautiful ergonomic construction & rounded corners
- Digital temperature controller and read-out
- All stainless steel exterior and interior
- Forced air refrigeration system
- Recessed drawer handles
- Pre-installed casters and shelving
- Drawers with stainless steel drawer slides and nylon wheels
- 90 degree hold open door feature for loading products
- Optional Accessory: Backsplash for Work-Tops for in-the-field installment\*\*, Taller 6" casters available\*\*\*
- All Natural R290 Hydrocarbon Refrigerant
- US Department of Energy Certified
- Migali® Protection Plan: 2 Year Parts & Labor Warranty, 5 Years Compressor Warranty

MODEL	DAWERS	CAPACITY CU/FT	SHELVES	H/P	AMPS	VOLTAGE	ENERGY CONSUMPTION KWH/24 HR	PLUG TYPE	TEMP RANGE	EXTERIOR DIMENSIONS W X D X H*	INTERIOR DIMENSIONS W X D X H	PACKAGED DIMENSIONS W X D X H	WEIGHT	PACKAGED WEIGHT
C-U27R-D-HC	2	6.5	2	1/7+	2.3	115/60/1	0.83	Nema 5-15P	+33°F (-) +41° F	27.5 x 30 x 34.1	23.9 x 23.6 x 26.7	29 x 32 x 39	137 lbs.	172 lbs.
C-U48R-D-HC	4	12	4	1/7+	2.3	115/60/1	1	Nema 5-15P	+33°F (-) +41° F	48.25 x 30 x 34.1	44.7 x 23.6 x 26.7	50 x 32 x 39	192 lbs.	232 lbs.
C-U60F-D-HC	4	17.9	4	1/5	2.8	115/60/1	1.2	Nema 5-15P	+33°F (-) +41° F	60.25 x 30 x 34.1	56.7 x 23.6 x 26.7	63 x 32 x 39	219 lbs.	265 lbs.

\* Total height includes casters

\*\*Accessories: Stainless Steel Back Splash - BS27 - 27" wide / BS48 - 48" wide / BS60 - 60" wide

\*\*\* Optional 6" casters available - Part # 1759-208

FOR COMMERCIAL USE ONLY

NOTE: MIGALI® RESERVES THE RIGHT TO CHANGE SPECIFICATIONS WITHOUT NOTICE



WEB: [www.lfsusa.store](http://www.lfsusa.store)



# DIMENSIONAL DRAWINGS

C-U27F-D-HC

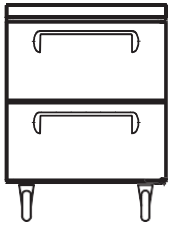

C-U48F-D-HC

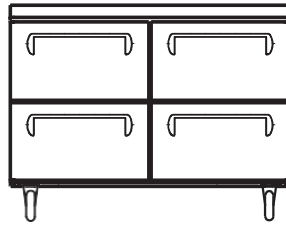

C-U60F-D-HC

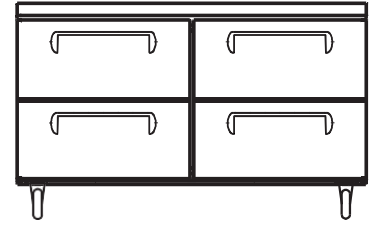

C-U27F-D-HC  
TOP VIEW

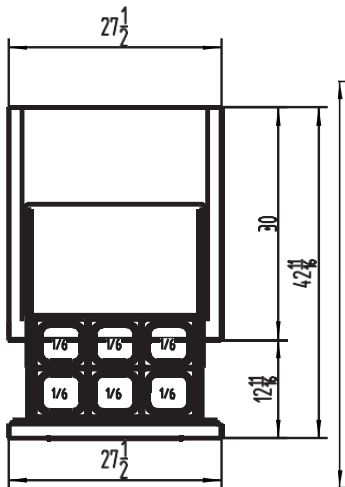

C-U48F-D-HC  
TOP VIEW

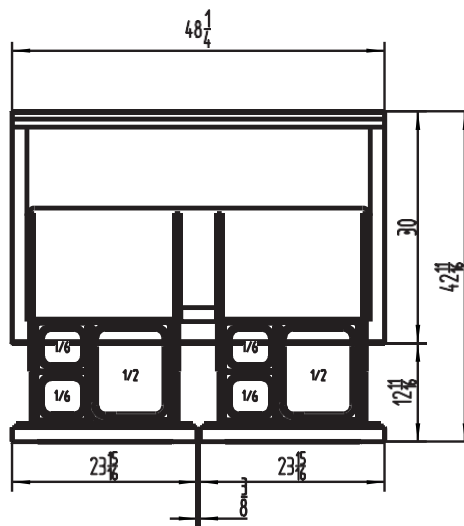

C-U60F-D-HC  
TOP VIEW

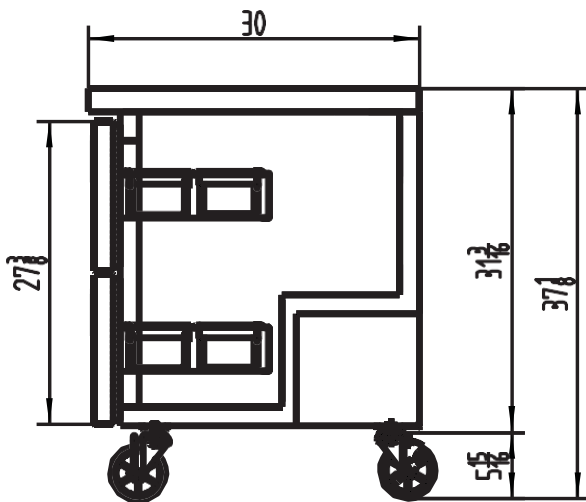
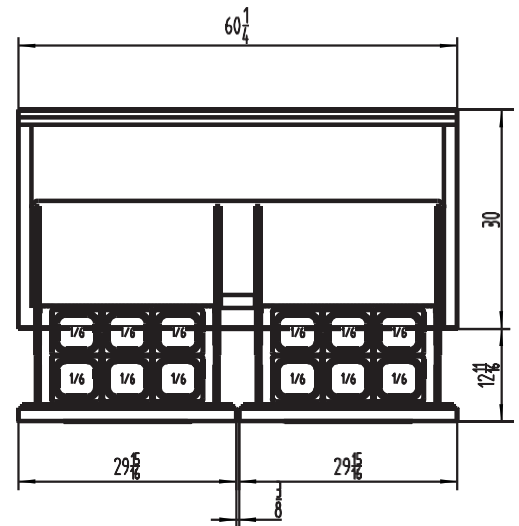

SIDE VIEW (2,4) DRAWER MODELS



MIGALI® REMAINS AN AMERICAN FAMILY COMPANY SINCE 1955